



AISG Connector Specification

AISG C485

Revision History

DATE	ISSUE	NOTES
10 December 2015	1.0	First Release

© Copyright AISG Ltd 2015

Antenna Interface Standards Group
Standard No. AISG C485
V1.0
10th of December, 2015



Content

1	General	4
1.1	Foreword	4
1.2	Scope	4
1.3	General information	4
1.4	Quality requirements	4
2	Normative references	4
3	Technical Information	5
3.1	Definitions	5
3.2	Number of contacts	5
3.3	Marking	5
3.4	Safety aspects	5
4	Dimensions	5
4.1	Survey of styles and variants	5
4.1.1	Fixed connectors	5
4.1.2	Free connectors	11
4.1.3	Protective caps	12
4.2	Dimensions	13
4.2.1	Interface dimensions	13
4.2.2	Pin front view of male connector and contact position	15
4.2.3	Pin front view of female connector and contact position	15
4.3	Gauges	16
4.3.1	Sizing gauges and retention force gauges	16
5	Characteristics	16
5.1	Climatic category	16
5.2	Electrical characteristics	17
5.2.1	Rated Voltage - Rated impulse withstand voltage - Pollution degree	17
5.2.2	Voltage between contacts and housing	17
5.2.3	Current carrying capacity	17
5.2.4	Contact resistance	17
5.2.5	Insulation resistance	17
5.2.6	Surge current capability	18
5.2.7	Measurement of screening attenuation	18
5.3	Mechanical characteristics	19
5.3.1	IP degree	19
5.3.2	Mechanical operation	19
5.3.3	Insertion and withdrawal forces	19
5.3.4	Polarizing method	19
5.3.5	Vibration	19
5.3.6	Shock	20
5.3.7	Cable retention	20
5.3.8	Tightening torque	20
5.4	Environmental conditions	20
5.4.1	Salt mist resistance	20
5.4.2	Exposure to sunlight and rain	20
5.5	Materials	20
5.5.1	Contact surface	21
5.5.2	Housing surface	21
5.5.3	Contacts inserts	21
6	Assembly instructions	21
7	Test requirements	21
7.1	General	21
7.1.1	Arrangement for contact resistance measurements	22

Antenna Interface Standards Group

Standard No. AISG C485

V1.0

10th of December, 2015



7.1.2	Arrangement for vibration and shock tests	22
7.1.3	Arrangement for IP 68 testing	23
7.1.4	Test for cable retention	23
7.2	Test requirements	24
7.2.1	Test group TG - Preliminary	24
7.2.2	Test group TG A – Dynamic/ Climatic	25
7.2.3	Test group TG B – Mechanical endurance	27
7.2.4	Test group TG C – Electrical characteristics	28
7.2.5	Test group TG D – environmental conditions	28
7.2.6	Test group SP – connection method tests	29

Antenna Interface Standards Group

Standard No. AISG C485

V1.0

10th of December, 2015



1 General

1.1 Foreword

The Antenna Interface Standards Group (AISG) published this AISG standard to describe and define the AISG connector for RS-485 (AISG C485) (based on IEC 60130-9), typically used for AISG outdoor applications. Different connector vendors and connector styles are used within the control infrastructure of antennas and antenna line products, such as RET, TMA, Sensor- and Monitoring- devices. Outdoor connector applications require good protection against environmental conditions to ensure waterproofness.

1.2 Scope

The purpose of this standard is to define the mechanical interface and outline to ensure compatibility between different connector vendors and styles, and to specify the test requirements for the quality assessment of the connectors.

Using this specification for connector design and selection will substantially increase the quality of AISG connectors.

1.3 General information

This Standard describes circular connectors with IP 68 protection degree (definition see 5.3.1). These connectors consist of fixed and free connectors, either rewirable or non-rewirable, with M16 x 0,75 screw-locking.

Male connectors have round contacts \square 1,5 mm.

The contact terminations shall be of the following types: crimp or solder.

1.4 Quality requirements

Quality assessment and type approval shall be performed according to the test requirements in chapter 7. Tests must take place in an independent and accredited test house. It is not permitted to refer to this standard on any product that has not been type approved according to the standard.

2 Normative references

The following referenced documents are indispensable for the application of this document. For dated references, only the edition cited applies. For undated references, the latest edition of the referenced document (including any amendments) applies.

IEC 60050-581, *International Electrotechnical Vocabulary – Part 581: Electromechanical components for electronic equipment*

IEC 60068-1:1988, *Environmental testing – Part 1: General and guidance* Amendment 1 (1992)

IEC 60352-2, *Solderless connections – Part 2: Crimped connections – General requirements, test methods and practical guidance*

IEC 60512 (all parts), *Connectors for electronic equipment – Tests and measurements*

IEC 60512-1-100, *Connectors for electronic equipment – Tests and measurements – Part 1-100:General – Applicable publications*

IEC 60529:1989, *Degrees of protection provided by enclosures (IP code)*

IEC 60664-1:2007, *Insulation coordination for equipment within low-voltage systems – Part 1:Principles, requirements and tests*

IEC 61076-1, *Connectors for electronic equipment Product requirements – Part 1: Generic specification*

IEC 61076-2, *Connectors for use in d.c., low-frequency analogue and digital high speed data applications - Part 2: Circular connectors with assessed quality - Sectional specification*

IEC 61984:2008, *Connectors – Safety requirements and tests*

ISO 1302, *Geometrical Product Specifications (GPS) – Indication of surface texture in technical product documentation*

IEC 61000-4-5:2014, *Electromagnetic compatibility (EMC) - Part 4-5: Testing and measurement techniques - Surge immunity test*

IEC 62305-1:2010, *Protection against lightning - Part 1: General principles*

3 Technical Information

All dimensions are in mm. All drawings are drawn in the first angle projection.

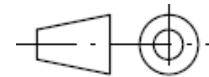

The connectors do not need to comply with the illustration, only the shown dimensions must be correct.

In the test cases with the free connector an appropriate cable with shielding shall be used, which fulfills all electrical and mechanical requirements mentioned in the text

3.1 Definitions

For the purposes of this International Standard, the terms and definitions given in IEC 60050-581 apply.

3.2 Number of contacts

4 or 5 contacts with max. crimp termination for wire gauge 0,75mm (AWG18) and max. solder termination 0,5mm² (AWG 20)

3.3 Marking

The marking of the connector and the package shall be in accordance with 2.6 of IEC 61076-2.

3.4 Safety aspects

For safety aspects IEC 61984 shall be considered unless otherwise specified.

4 Dimensions

4.1 Survey of styles and variants

4.1.1 Fixed connectors

Style	Description
A1	Fixed connector, rear panel mounting, male contacts
A2	Fixed connector, flange mounting, male contacts
A3	Fixed connector, rear panel mounting, female contacts
A4	Fixed connector, flange mounting, female contacts
A5	Fixed connector, rear panel mounting, male contacts, prolonged shell
A6	Fixed connector, rear panel mounting, female contacts, prolonged shell
A7	Fixed connector, flange mounting, male contacts, prolonged shell

4.1.1.1 Style A1

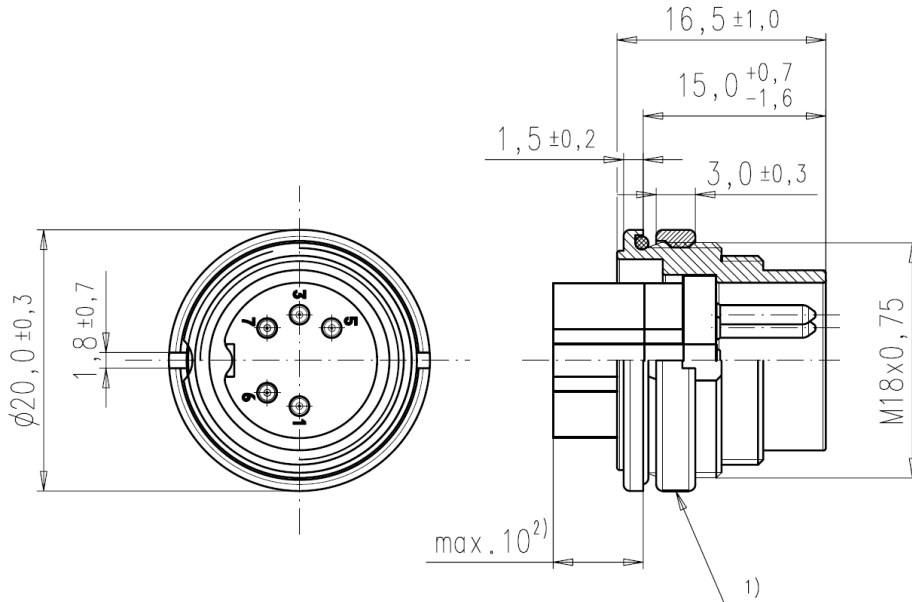

- 1) With ring or hexagonal nut width across flats 20 (\varnothing D 23,1 max.).
- 2) Totally length of the connector including solder pins, glue or overmolding

4.1.1.2 Style A2

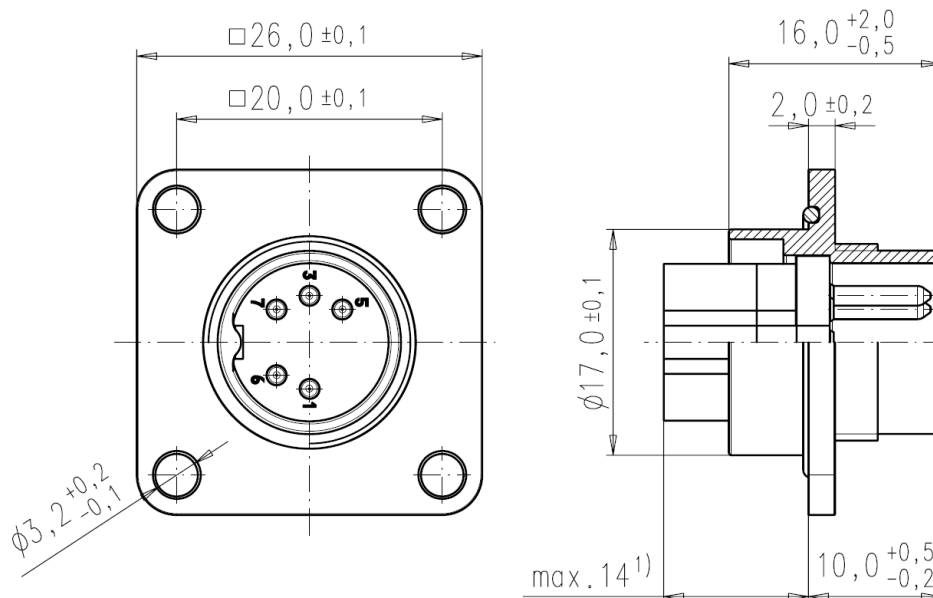

- 1) Totally length of the connector including solder pins, glue or overmolding

4.1.1.3 Style A3

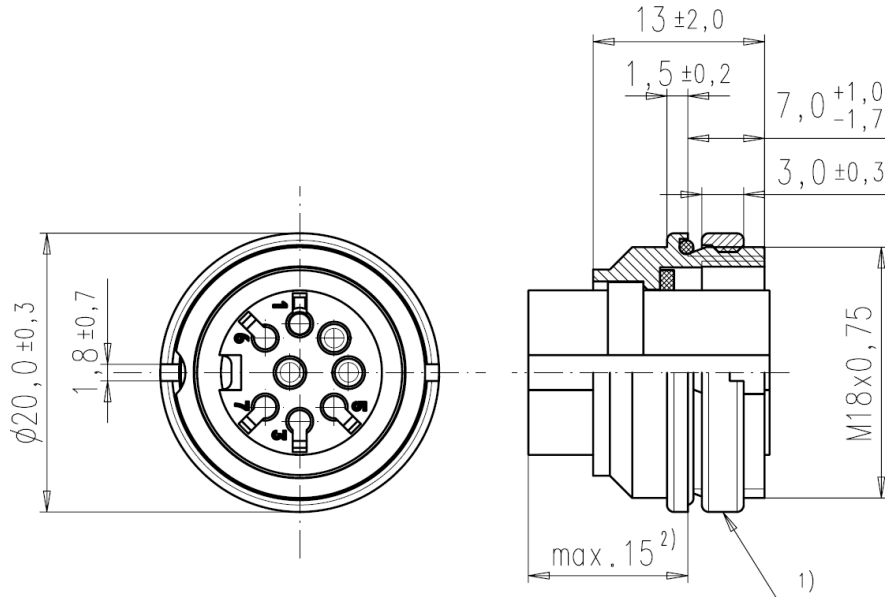

- 1) With ring or hexagonal nut width across flats 20 (\varnothing D 23,1 max.).
- 2) Totally length of the connector including solder pins, glue or overmolding

4.1.1.4 Style A4

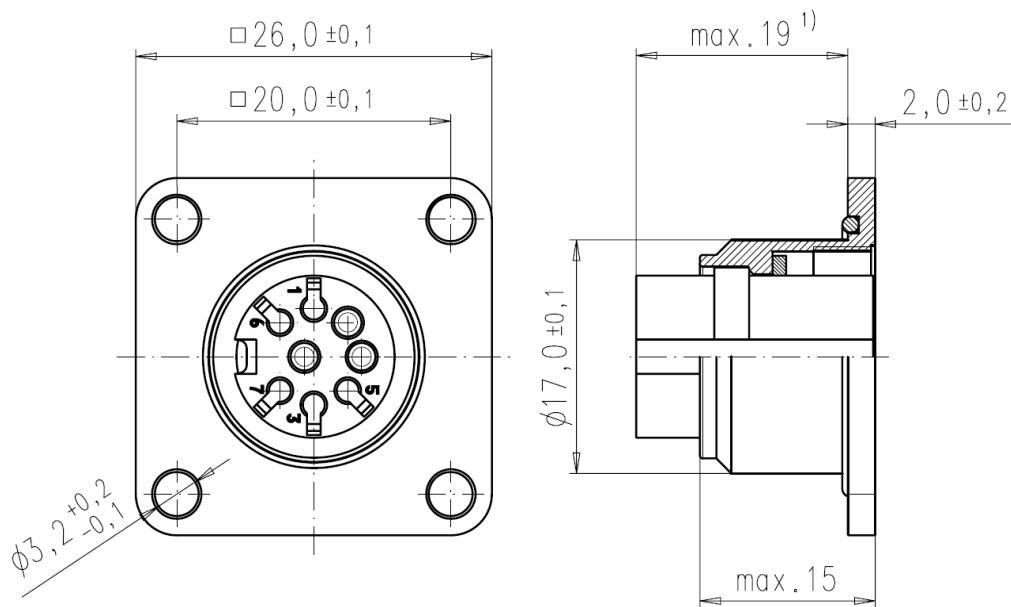

- 1) Totally length of the connector including solder pins, glue or overmolding

4.1.1.5 Style A5

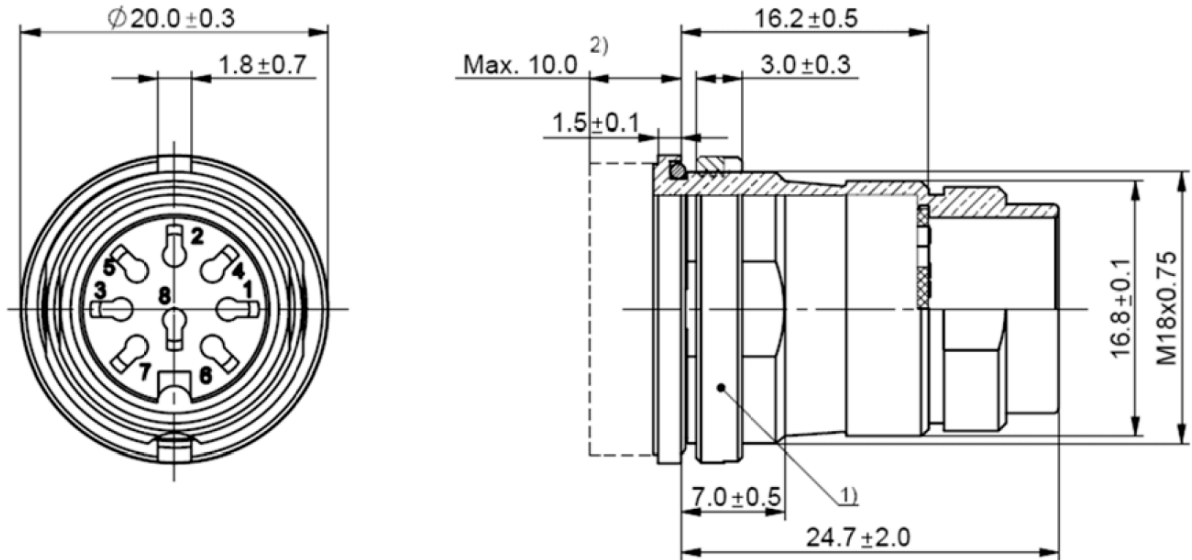

- 1) With ring or hexagonal nut width across flats 20 (ϕ D 23,1 max.).
- 2) Totally length of the connector including solder pins, glue or overmolding

4.1.1.6 Style A6

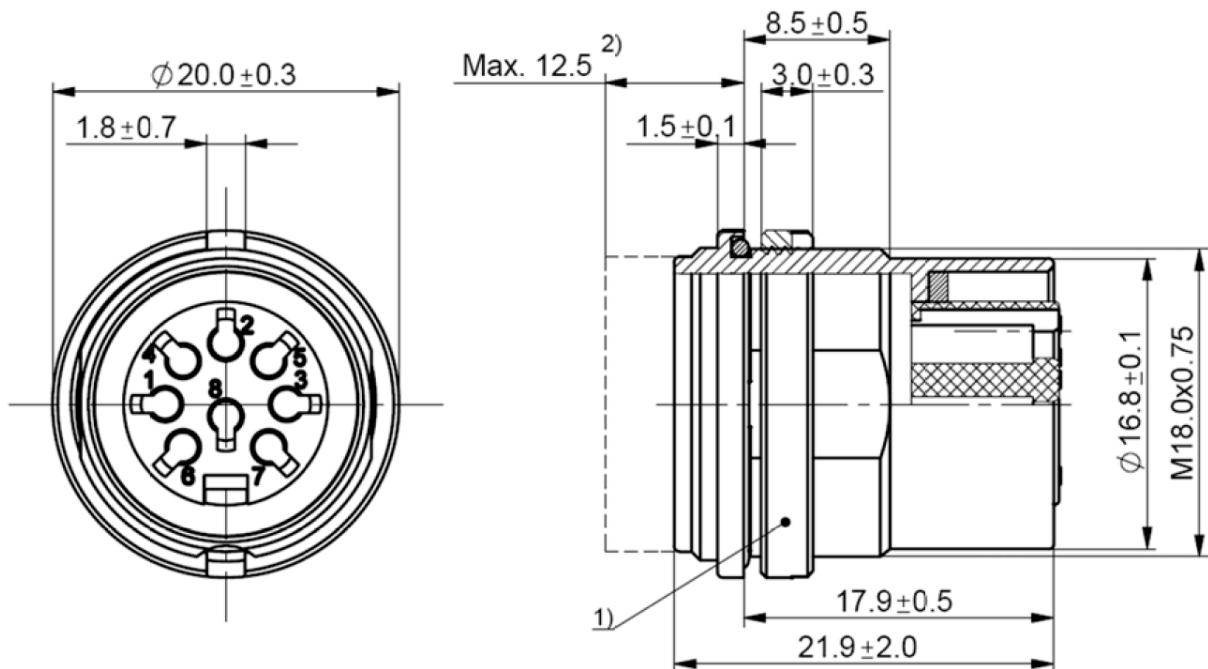

- 1) With ring or hexagonal nut width across flats 20 (ϕ D 23,1 max.).
- 2) Totally length of the connector including solder pins, glue or overmolding

Antenna Interface Standards Group
Standard No. AISG C485
V1.0
10th of December, 2015



4.1.1.7 Style A7

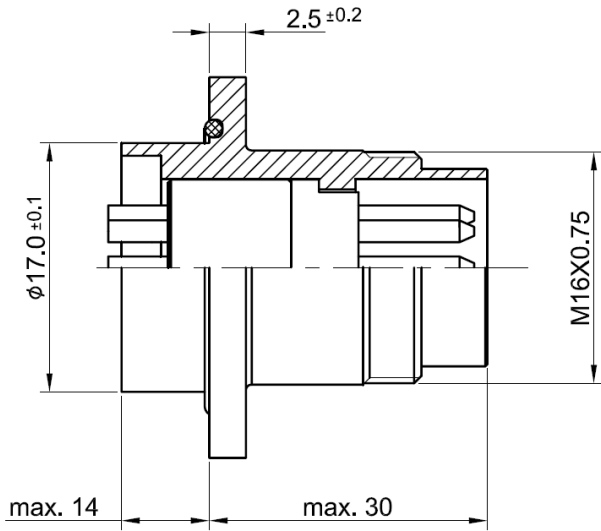
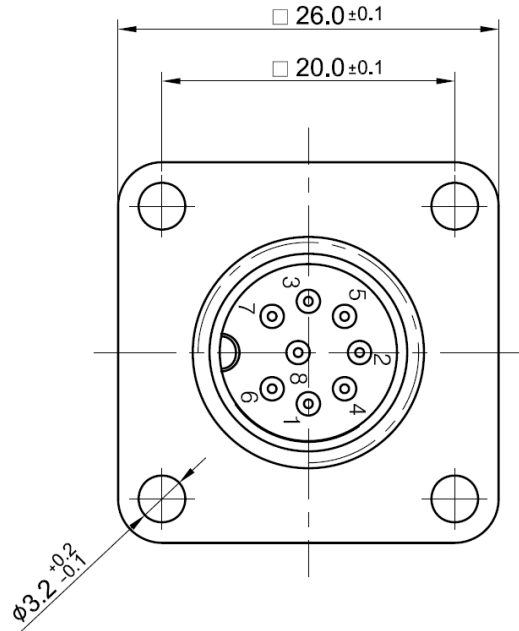

4.1.1.8 Panel Cutout

Recommended characteristics for the sealing surface:

- roughness Rz6.3 (Ra 0,8) (according DIN ISO EN 4287)
- unevenness max. 0,1mm
- max. chamfer 0,1mm

panel cutout for Style A1, A3, A5 and A6

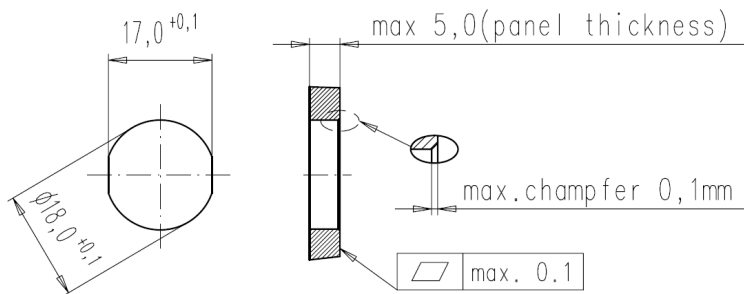

panel cutout for Style A2, A4 and A7

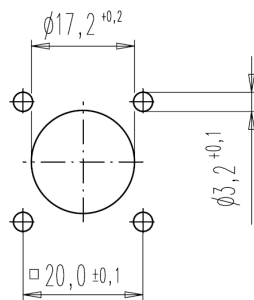

4.1.2 Free connectors

Style	Description
Af1	Free connector, rewireable, straight version, male contacts, cable diameter 6,5-8mm ¹⁾
Af2	Free connector, rewireable, straight version, female contacts, cable diameter 6,5-8mm ¹⁾

¹⁾ Recommend value

4.1.2.1 Style Af1

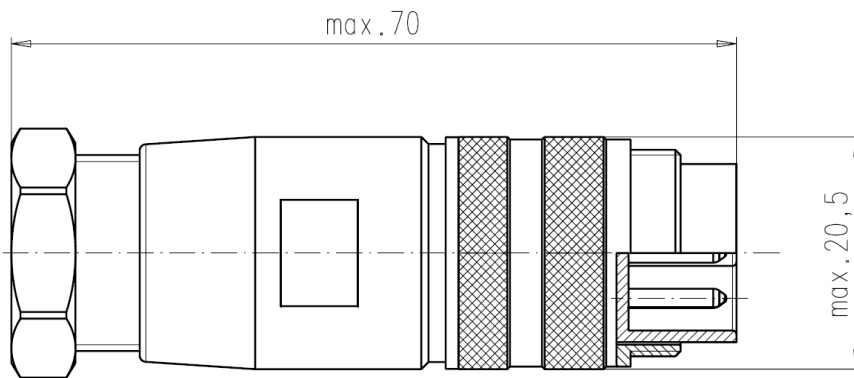

4.1.2.2 Style Af2

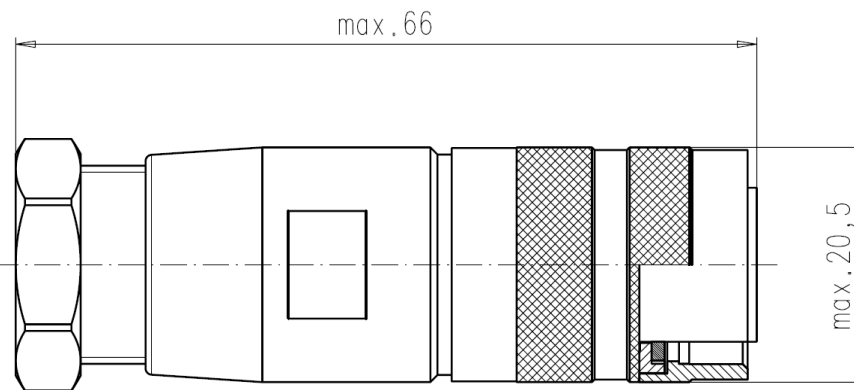

4.1.3 Protective caps

All protective caps can be used with a cord or a chain in different length, to fix them at the panel or at the cable.

4.1.3.1 Protective cap for female connectors fixed and free

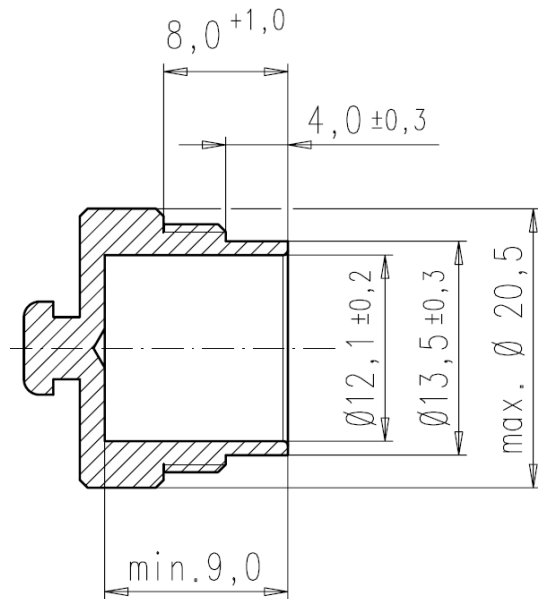

4.1.3.2 Protective cap for male connectors fixed and free

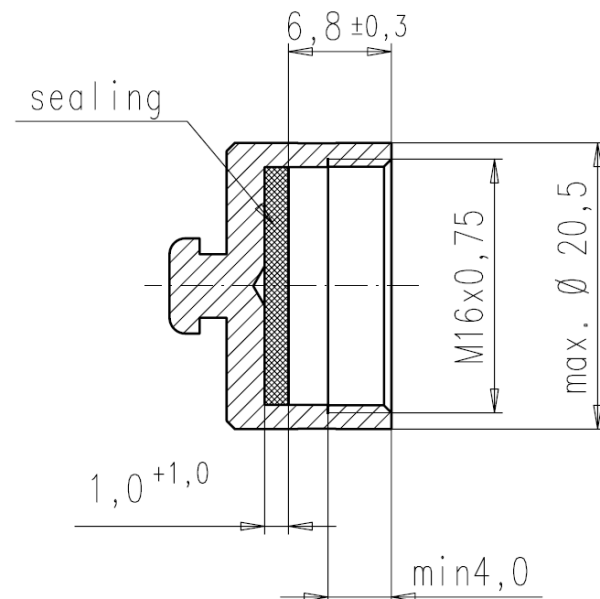

4.2 Dimensions

4.2.1 Interface dimensions

The shapes of the shown sealings are only for reference; the real shape depends on designer. The sealings are shown in the uncompressed state, so the dimensions related to the sealings are measured in the uncompressed state.

4.2.1.1 Fixed connector male

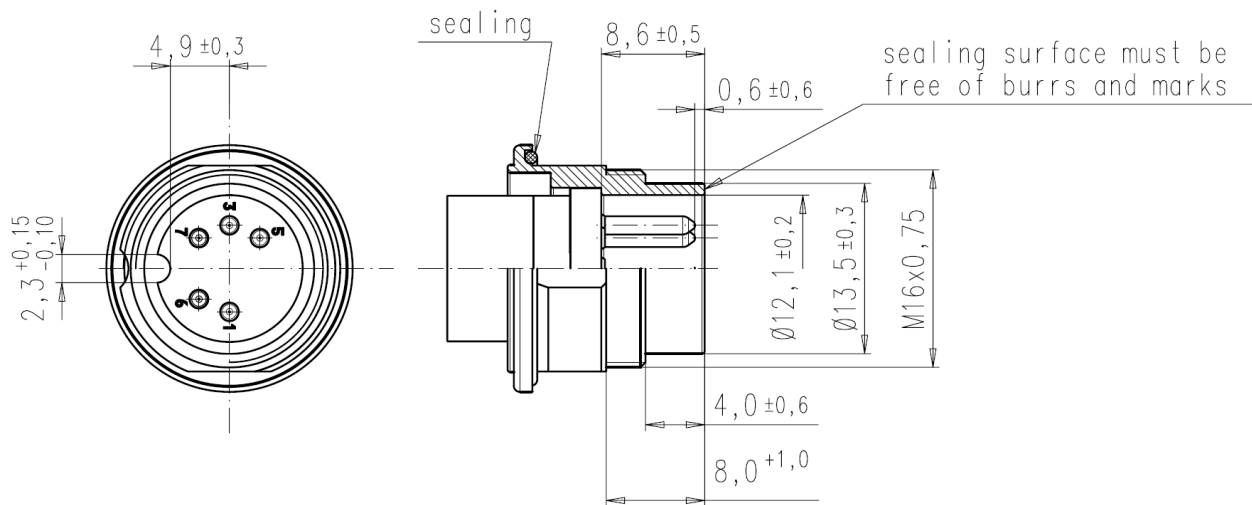

4.2.1.2 Fixed connector female

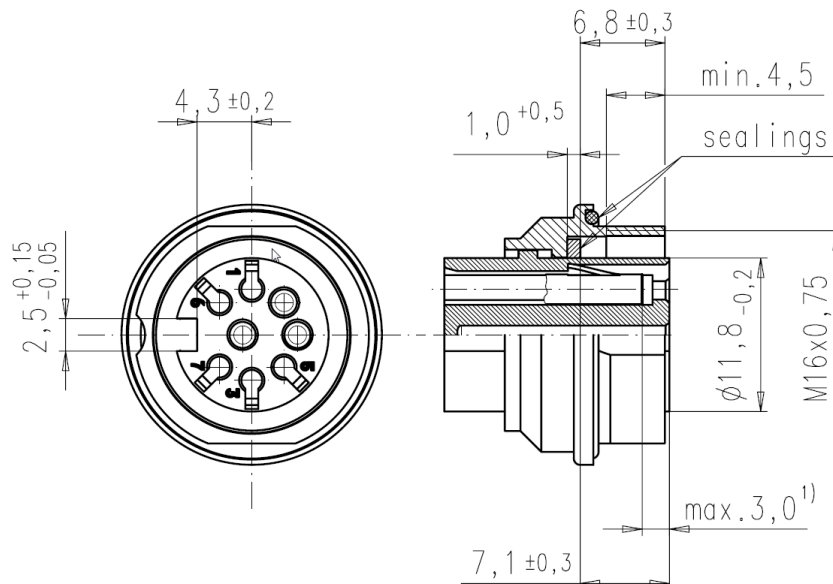

1) dimension describes position of the contact point

4.2.1.3 Free connector male

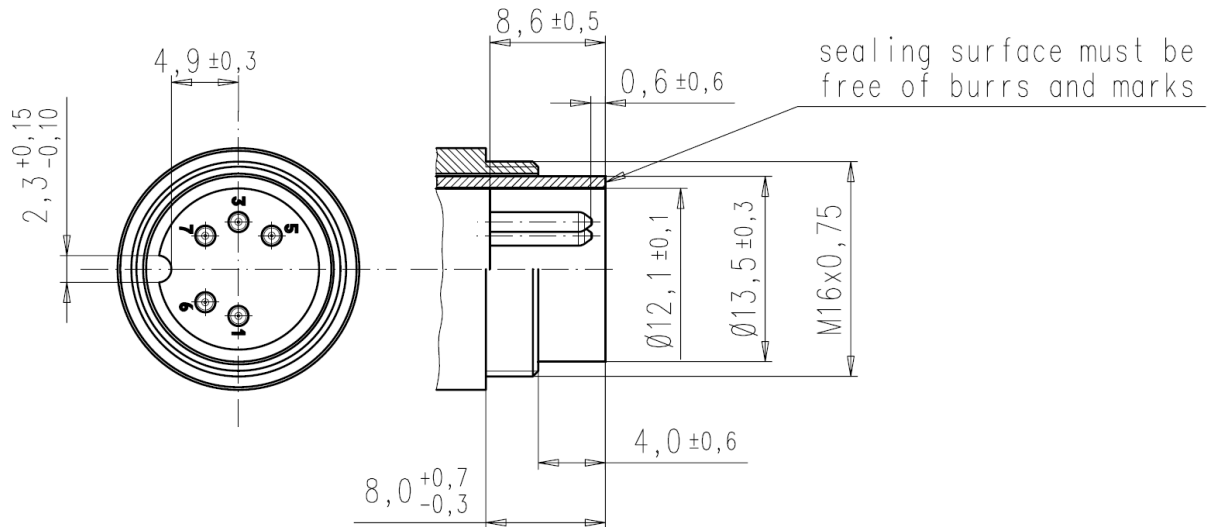

4.2.1.4 Free connector female

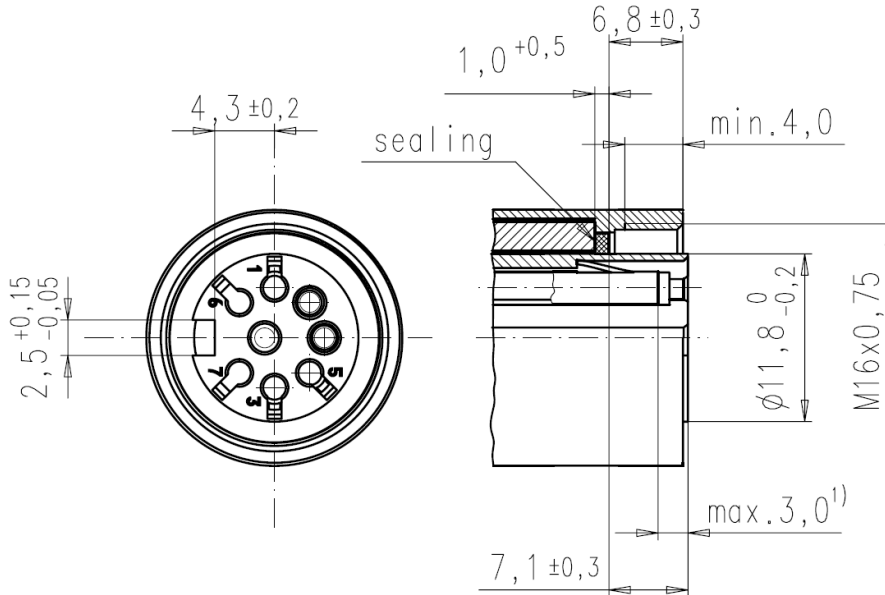

1) dimension describes position of the contact point

4.2.2 Pin front view of male connector and contact position

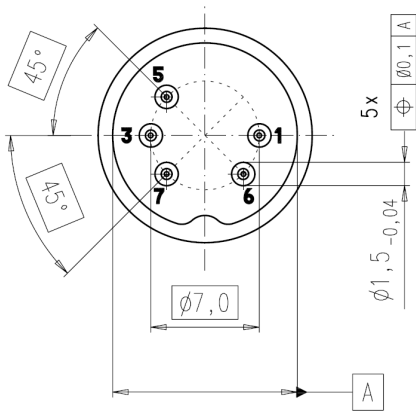

Male pin layout is based on DIN EN 61076-2-106:2012-04 variant 08-a. The male pins 2,4 and 8 are not in use for AISG applications.

Male pin 1 shall not be used for new constructions, only needed to keep compatibility to older versions.
 Pin assignment according AISG specification.

4.2.3 Pin front view of female connector and contact position

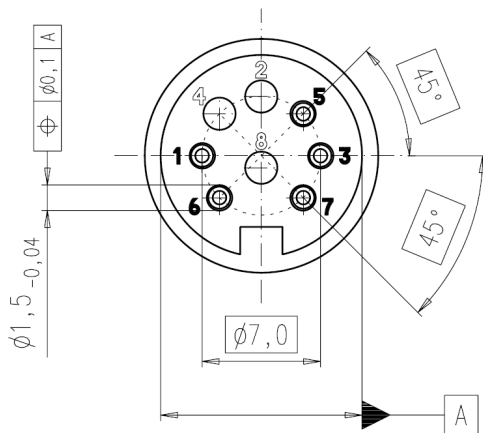

Female pin layout is based on DIN EN 61076-2-106:2012-04 variant 08-a. The female pins 2,4 and 8 are not in use for AISG applications, but it must be ensured that fully loaded male connectors according DIN EN 61076-2-106:2012-04 variant 08-a are pluggable.

Male pin 1 shall not be used for new constructions, only needed to keep compatibility to older versions.
 Pin assignment according AISG specification.

4.3 Gauges

4.3.1 Sizing gauges and retention force gauges

Material: tool steel, hardened

 = Surface roughness according to ISO 1302: Ra = 0,25 µm max. 0,15 µm min.

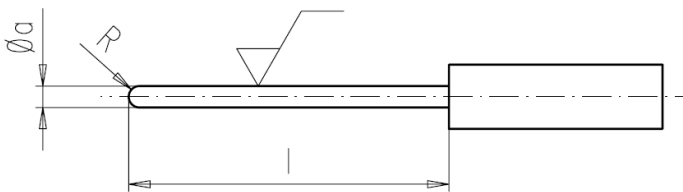

Gauge	Mass g	Application	Ø a mm	l min. mm
G11	-	Sizing	1,53	10
G12	20	Retention force	1,47	10

See 7.2.2 test TG A2 under application

5 Characteristics

5.1 Climatic category

Conditions: IEC 60068-1

Climatic Category	Category of temperature		Damp heat steady-state		Days
	Lower °C	Upper °C	Temperature °C	Relative Humidity %	
40/85/21	-40	+85	40	93	21

Antenna Interface Standards Group

Standard No. AISG C485

V1.0

10th of December, 2015



5.2 Electrical characteristics

5.2.1 Rated Voltage - Rated impulse withstand voltage - Pollution degree

Conditions: IEC 60664-1

The permissible rated voltage depends on the application or specified safety requirement. Reductions in creepage or clearance distances may occur due to the printed board or wiring used and shall be duly taken into account.

Rated Voltage: 32V
Rated impulse withstand voltage: 0,8kV
Pollution degree: 3¹⁾

¹⁾ The rated voltage and impulse voltage are based on pollution degree 2. This results from application of the rules from IEC 60664-1.

5.2.2 Voltage between contacts and housing

Conditions:

- IEC 60512-4-1, Test 4a
- Standard atmospheric conditions
- Mated connectors

Impulse withstand voltage between contacts and between contacts and metal housing 500V

5.2.3 Current carrying capacity

Conditions:

- IEC 60512, Test 5a
- All contacts
- Values at 40 °C ambient temperature
- 0,5mm² wire gauge 5 A

5.2.4 Contact resistance

Conditions:

- IEC 60512, Test 2a
- Standard atmospheric conditions
- Connecting points see 7.1.1

Contact resistance $\leq 5\text{m}\Omega$

5.2.5 Insulation resistance

Conditions:

- IEC 60512, Test 3a, Method A
- Standard atmospheric conditions

Insulation resistance $\geq 10^8\Omega$

5.2.6 Surge current capability

5.2.6.1 Test conditions

This test is to be carried out on an assembled male/female connector pair. The test pulses and test method shall conform to IEC 61000-4-5 (8/20µs pulse) and IEC62305-1 (10/350µs pulse).

5.2.6.2 Test method

The following test pulses are to be applied to each contact and its associated crimp or solder termination in turn, in each case, applying one pulse every 60s:

- Five positive pulses with 8kA (8/20µs pulse form)
- Five negative pulses with 8kA (8/20µs pulse form)
- Five positive pulses with 2,5kA (10/350µs pulse form)
- Five negative pulses with 2,5kA (10/350µs pulse form)

The following test pulses are to be applied to the connector shield. The pulses are injected via the cable shield for free connectors (cable length ≤ 0,5m) and via the intended shield connection for fixed connectors. In each case, applying one pulse every 60s:

- Five positive pulses with 20kA (8/20µs pulse form)
- Five negative pulses with 20kA (8/20µs pulse form)
- Five positive pulses with 5kA (10/350µs pulse form)
- Five negative pulses with 5kA (10/350µs pulse form)

5.2.6.3 Performance criteria following conduct of the pulse tests:

The contacts and insulation between them shall not be damaged.

The contact resistance and contact insulation shall meet the criteria specified in Section 5.2.4 and 5.2.5 respectively.

5.2.7 Measurement of screening attenuation

The AISG RS-485 cable is required to be provided with a screen whose function is to isolate the cable cores from external electromagnetic fields. The effectiveness of the screening is a function both of the quality of the cable screen and of the integrity of the grounding provided by the connector.

5.2.7.1 Test conditions

The test is to be carried out on an assembly comprising a 0.5m length of screened cable terminated at each end by the connectors under test, each mated with an adaptor providing a screened transition to a single coaxial geometry, as shown in Figure 5.2.7.1-1.

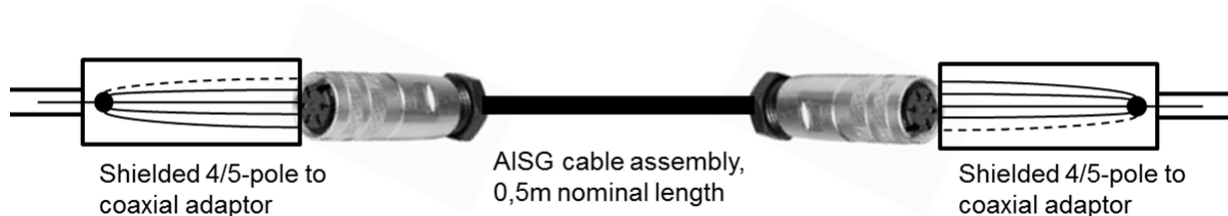

Figure 5.2.7.1-1

5.2.7.2 Test method

The test shall be performed using the absorbing clamp method specified in EN50083-2:2012 over the frequency

Antenna Interface Standards Group

Standard No. AISG C485

V1.0

10th of December, 2015



range 30–1000 MHz.

5.2.7.3 Performance criteria

The measured screening attenuation shall exceed the following values:

Frequency range	Screening attenuation
30–100 MHz	≥55 dB
100–1000 MHz	≥40 dB

5.3 Mechanical characteristics

5.3.1 IP degree

Conditions:

- Based on IEC 60529:1989 IP 68
- Before testing the samples must be subjected to a temperature changing test with the following key data
 - o Lower storage temperature -40°C
 - o Upper storage temperature +70°C
 - o Storage time 30 min
 - o Rate of temperature change 1K/min
 - o Cycles 50

Samples must pass test according 7.1.3

5.3.2 Mechanical operation

Conditions:

- IEC 60512, Test 9a
- Standard atmospheric conditions
- Max. speed of operations = 10 mm/s
- Rest: 30 s, unmated

Mechanical operations > 100

5.3.3 Insertion and withdrawal forces

Conditions:

- IEC 60512, Test 13b
- Standard atmospheric conditions
- Max. speed = 10 mm/s

Total insertion force max. 60N
Total withdrawal force max. 60N

5.3.4 Polarizing method

Conditions: IEC 60512, Test 13e

Engaging force: 1,5 x total insertion force but 35 N min.

5.3.5 Vibration

Conditions:

- IEC 60512, Test 6d
- Standard atmospheric conditions

Antenna Interface Standards Group

Standard No. AISG C485

V1.0

10th of December, 2015



- Connectors in mated and locked position
- The fixed and free connector shall be rigidly installed in a suitable fixture as specified in 7.1.2

Vibration Severity: 10 Hz to 500 Hz and 0,35 mm or 5 g

5.3.6 Shock

Conditions:

- IEC 60512 Test 6c
- Connectors in mated and locked position
- The fixed and free connector shall be rigidly installed in a suitable fixture as specified in 7.1.2

Half sine shock acceleration 490m/s² (50g)

Duration of impact: 11ms

5.3.7 Cable retention

Conditions:

- IEC 61984:2008 table 6

Retention force 80 N

Torque 0,1 Nm

5.3.8 Tightening torque

The tightening torque of the coupling nut must be between 1 – 1,5Nm.

If possible a suitable tool must be available to apply the correct torque.

5.4 Environmental conditions

5.4.1 Salt mist resistance

Conditions:

- DIN IEC 60068 part 2-11, test Ka
- Connectors in mated and locked position
- 5% NaCl
- Temperature 35°C
- Continuous spraying

Duration 720h

5.4.2 Exposure to sunlight and rain

Conditions:

- DIN EN ISO 4892-2 Procedure A1

Duration 500h

5.5 Materials

Antenna Interface Standards Group

Standard No. AISG C485

V1.0

10th of December, 2015



5.5.1 Contact surface

The contact surfaces of male and female pins shall be plated with gold or silver.

5.5.2 Housing surface

It is recommended to use Nickel as surface material. If another material is used the galvanic contact potential should not differ more than 0,25V from Nickel. Non metallic coatings are also allowed, if they are not influencing the shielding characteristics.

5.5.3 Contacts inserts

The flammability class of the plastic material for the contact inserts must be according UL 94V0.

6 Assembly instructions

Assembly instructions for the cable connectors must be available (e.g. on the connector manufacturer website, printed on the package or printed on a separate instruction for each bulk package)

7 Test requirements

7.1 General

This section shows the tests and the order in which they shall be carried out as well as the requirements to be met.

Unless otherwise specified, all tests shall be carried out under standard atmospheric conditions for testing as specified in IEC 60068-1, as directed by the applicable part of IEC 60512.

Unless otherwise specified, mated and locked sets of connectors shall be tested. Care shall be taken to keep a particular combination of connectors together during the complete test sequence, i.e. when unmating is necessary for a certain test, the same connector styles as before shall be mated for the subsequent tests. To get repeatable and comparable test results the cable connectors must be assembled with an appropriate cable.

All the tests with free connectors and its associated cables must be carried out with the recommended max and min specified cable diameter.

In the following, a mated and locked set of connector styles is called a specimen.

When the initial tests have been completed, all the specimens are divided in the 4 test groups TG A, TG B, TG C and TG D. In addition 20 single contacts are used for SP.

Before testing commences, the connectors shall be stored for at least 24 h in the non-engaged state under standard atmospheric conditions as per IEC 60068-1.

	Test groups					
	TG	TG A	TG B	TG C	TG D	SP
Number of specimen	20	5	5	5	5	20 single contacts

7.1.1 Arrangement for contact resistance measurements

Conditions: see 5.2.4

The measurement of contact resistance shall be carried out on the number of contacts specified and between the connector shielding and the housing. Any subsequent measurements of contact resistance shall be made on the same contacts.

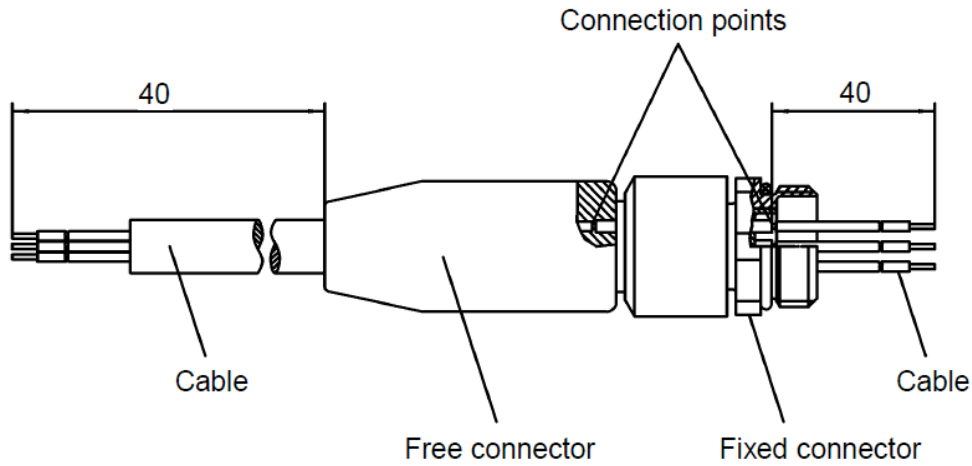

7.1.2 Arrangement for vibration and shock tests

Conditions: see 5.3.5 and 5.3.6

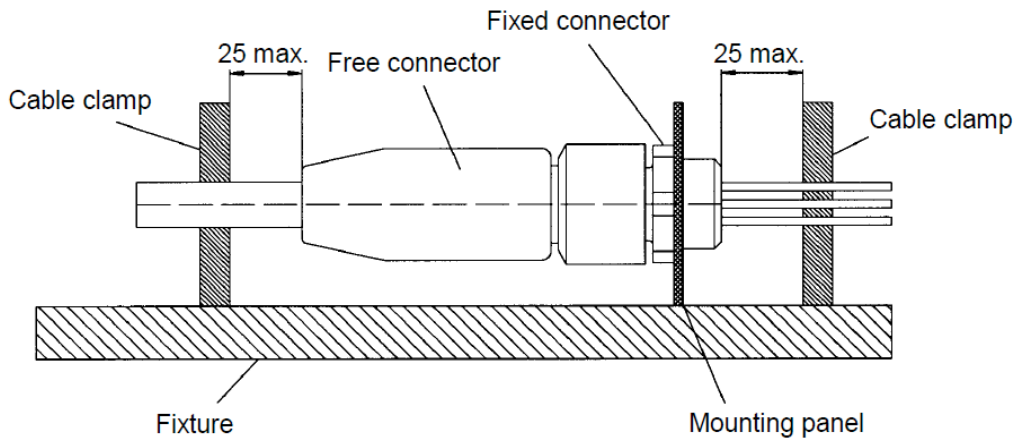

Antenna Interface Standards Group Standard No. AISG C485

V1.0

10th of December, 2015



7.1.3 Arrangement for IP 68 testing

Attach the test samples to the test cube and tighten the screw rings to the recommended torque.. Put the test cube under pressure with 0,2bar. After this put the cube into a water bowl so that the cube is fully covered with water.

In unmoved condition no bubbles must be visible. Test duration 5s.

In moved condition, means the connector must be fixed in the water bowl and the cable must be moved from 30° to max.45° for five times back and force holding 10cm behind the connector end. No bubbles must be visible.

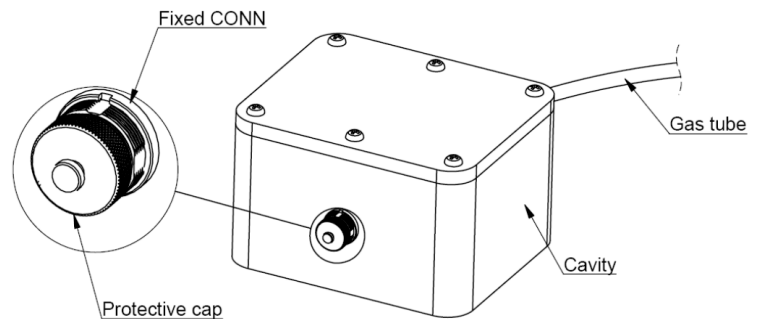
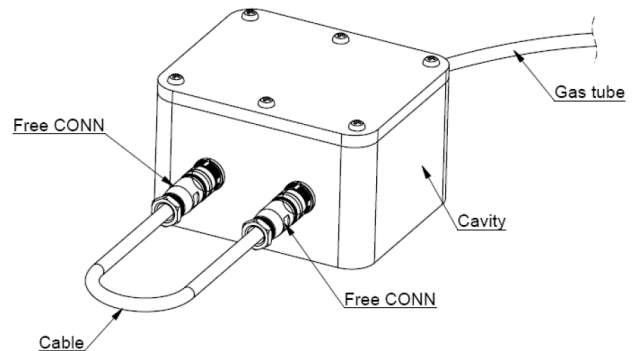

7.1.4 Test for cable retention

With the connector body fixed, apply a constant force F (80N) on the cable parallel to the centerline of the connector. After 1min the maximal movement of the cable shall be not more than 3mm.

Apply a constant torque D (0,1Nm) on the cable in the shown direction. After 1 min the maximal rotation of the cable relative to the connector shall be not more than 30°.

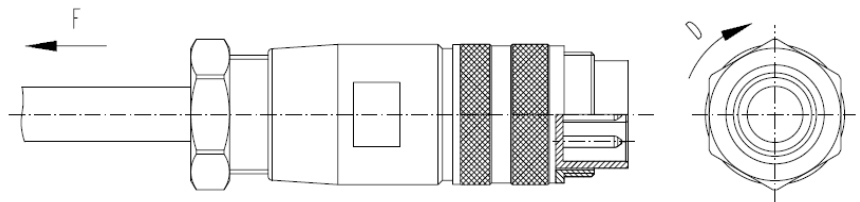

**Antenna Interface Standards Group
Standard No. AISG C485**

V1.0

10th of December, 2015



7.2 Test requirements

7.2.1 Test group TG - Preliminary

Test phase	Test			Measurement to be performed		Requirements
	Title	IEC 60512 Test No.	Severity or Condition of test	Title	IEC 60512 Test No.	All connector styles
TG 1	General examination	1	Unmated connectors	Visual examination	1a	There shall be no defect that would impair normal operation
				Dimensional examination	1b	The dimensions must be according to section 4
TG 2			Connection points according to 7.1.1 all contacts per specimens	Contact resistance – Millivolt level method	2a	Initial value acc.5.2.4
TG 3			Test voltage 500 V ± 15 V d.c. Method A	Insulation resistance	3a	Initial value acc.5.2.5
TG 4			Contact/ contact same measuring points as for P3	Voltage proof	4a	According to 5.2.2

The specimen shall be divided into 4 groups. All connectors in each group shall undergo the tests specified for the relevant group.

**Antenna Interface Standards Group
Standard No. AISG C485**

V1.0

10th of December, 2015



7.2.2 Test group TG A – Dynamic/ Climatic

Test phase	Test			Measurement to be performed		Requirements
	Title	IEC 60512 Test No.	Severity or Condition of test	Title	IEC 60512 Test No.	All connector styles
TG A1			See 5.3.3	Insertion and withdrawal forces	13b	Requirements see 5.3.3
TG A2	Gauge retention force		3 female contacts per specimen. For sizing and retention force gauge see 4.3.1	Engaging and separating forces	16e	See 4.3.1
TG A3	Vibration	6d	Sweep cycles: 10 Full duration: 6 h See 5.3.5	Contact disturbance	2e	Duration of disturbance 1 μ s max.
				Contact resistance – Millivolt level method	2a	Rise in relation to initial values \leq 10 m Ω
				Visual examination	1a	There shall be no defect that would impair normal operation
TG A4	Shock	6c	See 5.3.6	Contact disturbance	2e	Duration of disturbance 1 μ s max.
				Contact resistance – Millivolt level method	2a	Rise in relation to initial values \leq 10 m Ω
				Visual examination	1a	There shall be no defect that would impair normal operation
TG A5	IP protection degree		See 5.3.1	IP degree See 7.1.3		See 7.1.3
TG A6	Climatic sequence					
TG A6.1	Dry heat	11i	Temperature: 85 °C Duration: 16 h	Insulation resistance at high temperature	3a	Initial value acc.5.2.5
TG A6.2	Damp heat, cyclic, first cycle	11m	Method Db Temperature: 40 °C Recovery time: 2 h	Visual examination	1a	There shall be no defect that would impair normal operation
TG A6.3	Cold	11j	Temperature: -40°C Duration: 2 h Recovery time: 2 h	Visual examination	1a	There shall be no defect that would impair normal operation

**Antenna Interface Standards Group
Standard No. AISG C485**

V1.0

10th of December, 2015



Test phase	Test			Measurement to be performed		Requirements
	Title	IEC 60512 Test No.	Severity or Condition of test	Title	IEC 60512 Test No.	All connector styles
TG A6.4	Damp heat, cyclic, remaining cycles	11m	Conditions according to A6.2 5 cycles Recovery time: 2 h	Contact resistance – Millivolt level method	2a	Rise in relation to initial values ≤ 10 m Ω
				Insulation resistance	3a	Initial value acc.5.2.5
				Voltage proof	4a	According to 5.2.2
				Insertion and withdrawal forces	13b	Requirements see 5.3.3
				Visual examination	1a	There shall be no defect that would impair normal operation
TG A7	IP protection degree after aging		See 5.3.1	IP degree See 7.1.3		See 7.1.3
TG A8				Visual examination	1a	There shall be no defect that would impair normal operation
TG A9	Polarizing method	13e	See 5.3.4			It shall be possible to correctly align and mate the appropriate mating connectors. It shall not be possible to mate the connectors in any other than the correct manner. The insertion and withdrawal forces acc.TG A1

**Antenna Interface Standards Group
Standard No. AISG C485**

V1.0

10th of December, 2015



7.2.3 Test group TG B – Mechanical endurance

Test phase	Test			Measurement to be performed		Requirements
	Title	IEC 60512 Test No.	Severity or Condition of test	Title	IEC 60512 Test No.	All connector styles
TG B1			Female contacts only 3 contacts/ specimen sizing and retention force gauge see 4.3.1	Gauge retention force	16e	See 4.3.1
TG B2	Mechanical operation (half of the specified number of operations)	9a	Speed 10 mm/s max. Rest 30 s (unmated) Operations see 4.3.2 Speed: 10 mm/s max. Rest time: 30 s (un- mated)	Visual examination	1a	There shall be no defect that would impair normal operation
TG B3	Damp heat steady state	11g		Contact resistance – Millivolt level method	2a	Rise in relation to initial values ≤10 mΩ
TG B4	Mechanical operation (remaining half of specified number of operations)	9a	See TG B2	Contact resistance – Millivolt level method	2a	Rise in relation to initial values ≤10 mΩ
				Insulation resistance	3a	Initial value acc.5.2.5
				Voltage proof	4a	According to 5.2.2
			Unmated connectors	Visual examination	1a	There shall be no defect that would impair normal operation
TG B5				Insertion and withdrawal forces	13b	For requirements, see 5.3.3
TG B6			Female contacts only 3 contacts/ specimen sizing and retention force gauge see 4.3.1	Gauge retention force	16e	See 4.3.1
TG B7	Cable reten- tion force		See 7.1.4	Cable retention force		See 7.1.4

**Antenna Interface Standards Group
Standard No. AISG C485**

V1.0

10th of December, 2015



7.2.4 Test group TG C – Electrical characteristics

Test phase	Test			Measurement to be performed		Requirements
	Title	IEC 60512 Test No.	Severity or Condition of test	Title	IEC 60512 Test No.	All connector styles
TG C1	Rapid change of temperature	11d	-40 °C to 85 °C r = 1h 5 cycles	Contact resistance – Millivolt level method	2a	Rise in relation to initial values ≤10 mΩ
				Insulation resistance	3a	Initial value acc.5.2.5
				Voltage proof	4a	According to 5.2.2
TG C2	Mechanical operation	9a	See TG B2			
TG C3	Electrical load and temperature	9b	Duration: 10h Amp.Temp.: 40 °C Current load according to 5.2.3 Recovery time: 2 h Temperature sensor in center of specimen	Contact resistance – Millivolt level method	2a	Rise in relation to initial values ≤10 mΩ
				Insulation resistance	3a	Initial value acc.5.2.5
				Voltage proof	4a	According to 5.2.2
TG C4	Shielding attenuation		See 5.2.7			According to 5.2.7
TG C5	Surge current capability		Test all contacts and shielding			According to 5.2.6
TG C6			Unmated connectors	Visual examination	1a	There shall be no defect that would impair normal operation

7.2.5 Test group TG D – environmental conditions

Test phase	Test			Measurement to be performed		Requirements
	Title	IEC 60512 Test No.	Severity or Condition of test	Title	IEC 60512 Test No.	All connector styles
TG D1	Salt mist resistance		See 5.4.1	Contact resistance – Millivolt level method	2a	Rise in relation to initial values ≤10 mΩ
				IP degree		See 7.1.3
				Insulation resistance	3a	Initial value acc.5.2.5
TG D2	exposure to sunlight and rain		See 5.4.2	Visual inspection	1a	There shall be no defect that would impair normal operation



7.2.6 Test group SP – connection method tests

Test phase	Test			Measurement to be performed		Requirements
	Title	IEC 60512 Test No.	Severity or Condition of test	Title	IEC 60512 Test No.	All connector styles
TG 1	Tensile strength (crimped connection)	16d	Test samples 5 male and 5 female crimped contacts, according to IEC 60352-2			