



Control interface for antenna line devices

Revision History

DATE	ISSUE	NOTES
29 th Oct 2003	1.0	First issue



CONTENTS

1	Foreword	5
2	Scope	6
3	References	8
4	Abbreviations	9
5	Terminology	10
6	Layer 1	12
6.1	Antenna line network	12
6.1.1.	Network current consumption	12
6.1.2.	Maximum ALD network current demand	12
6.1.3.	Overcurrent protection	12
6.2.	Interface Connector types	13
6.2.1.	Multi-pole connector	13
6.2.2.	Polarity of multi-pole connectors	13
6.2.3.	Coaxial connectors	13
6.3.	DC supply	14
6.3.1.	Supply voltage	14
6.3.2.	Noise and ripple	14
6.4.	Current consumption	14
6.4.1.	RET DC supply	14
6.4.2.	TMA DC supply	14
6.4.3.	ALD network DC supply	15
6.4.4.	ALD DC Supply Start-up Surge	15
6.4.5.	DC supply via LOC	15
6.4.6.	Re-start capability of the power supply at a primary station	17
6.5.	RS485 serial data bus	17
6.5.1.	Connections	17
6.5.2.	Device terminating impedance	17
6.5.3.	Bus terminating impedance	17
6.6.	Coaxial interface: modem characteristics	17
6.6.1.	Interference With Existing Systems	17
6.6.2.	Data Rate	18
6.6.3.	Recovery Time	18
6.6.4.	Impedance	18
6.6.5.	Modulation	18
6.6.6.	Modulator characteristics	18
6.6.6.1	Levels	18
6.6.6.2	Spurious emissions	18
6.6.7.	Demodulator characteristics	19
6.6.7.1	Threshold	19
6.6.7.2	Filter Characteristics	19
6.6.7.3	Duty Cycle variation	19
6.7.	Data rate & format	20
6.7.1.	Data Rate	20
6.7.2.	Data Format	20
6.8.	Resumption of operation after interruption of supply	20
6.8.1.	Device Type 1	20



6.8.2	Device Type 2	20
6.8.2.	Device Type 3	21
6.9.	Idle-state biasing	21
7.	Layer 2	22
7.1.	HDLC Format	22
7.1.1.	Operating Mode	22
7.1.2.	Control octet transparency	22
7.2.	Frame checking sequence (FCS) field	22
7.3.	HDLC Command Sub-set	22
7.3.1.	I-frame and INFO-field format	23
7.3.1.1	Parameter determination	23
7.3.2.	Version ID	25
7.3.3.	SNRM frame data format	25
7.4.	Address	25
7.4.1.	Address 0x00	25
7.4.2.	Address 0xFF	25
7.4.3	Address configuration	25
7.4.3.1	Address assignment command	25
7.4.3.2	Address Assignment Response	26
7.4.3.3	Device scan command	26
7.4.3.3.1	Primary command (XID frame)	26
7.4.3.3.2	Device Scan Response (XID)	26
7.5.	Window Size (minimum)	27
7.6.	Connection Establish	27
7.7.	Disconnect	27
7.8.	Polling	27
7.9.	Information	28
7.10.	Message timing	28
7.10.1.	Primary Station Poll	28
7.10.2.	Secondary Station Frame response	28
7.10.3.	Recovery Time	28
7.11.	Frame Error Rate	28
8.	Layer 7	29
8.1.	Command Format	29
8.2.	Response format and return codes	29
8.3.	Overview of commands	29
8.4.	Global Command Interface – Mandatory for all Devices	31
8.4.1.	Get Device Type	31
8.4.2.	Reset Software	32
8.4.3.	Error Detection	32
8.4.4.	Read Hardware and Software Information	32
8.4.5.	Clear stored Alarms	33
8.4.6.	Poll response from Secondary Station	33
8.4.7.	Enable Device	34
8.4.8.	Disable Device	34
8.4.9.	Self Test	35
8.4.10.	Read and Write Memory	35
8.4.10.1	Read Memory	35
8.4.10.2	Write Memory	36



8.4.11. Get supported bit rates	36
8.4.12. Set Device Data	37
8.4.13. Get Device Data	37
8.4.14. Software Download (Optional feature)	37
8.4.14.1. Download Start	38
8.4.14.2. Store Data Start	38
8.4.14.3. Store Data Block Segment	38
8.4.14.4. Download End	39
8.4.16. Optional command: Set bit rate	39
8.4.16.1. Set Bit Rate Procedure	40
8.5. Device Specific Commands for a RET	40
8.5.1. Calibration	40
8.5.2. Send RET Configuration data	41
8.5.3. Set Tilt	41
8.5.4. Get Tilt	42
8.6. Specific commands for a TMA	42
8.6.1. Set TMA Mode	42
8.6.2. Get TMA Mode	43
8.6.3. Set TMA Gain	43
8.6.4. Get TMA Gain	43
8.7. Vendor Specific Commands	44
8.8. Unknown Commands	44
8.9. Additional commands for control and telemetry	44
9. Additional requirements	45
9.1. Electromagnetic compatibility	45
9.2. Lightning protection	45
9.3. Reliability	45
10. Product identification	46
10.1. Marking of conforming products	46
10.2. Use of the AISG name and logo	46
10.3. Vendor ID and Serial Number	46
Appendix A: Assigned vendor codes	47
Appendix B: Assigned device types	48
Appendix C: Assigned return codes	49
Appendix D: Assigned fields for additional data	51
Appendix E: Sequence for download of software to a secondary station	53
Appendix F: Product specification compatibility	54



1 FOREWORD

This draft standard has been produced by the Antenna Interface Standards Group to facilitate the introduction of antenna line products with remote control and monitoring facilities.

The purpose of this standard is to ensure basic interoperability of antennas and control infrastructure.

At the date of publication of this document, the following companies were members of the Antenna Interface Standards Group:

Ace Technology Corp	Jaybeam Ltd
ADC, Inc	Kathrein KG
Alan Dick & Co Ltd	K&L Microwave Inc
Andrew Corporation	KMW Ltd
Argus Technologies (Australia) Pty Ltd	LGP Allgon AB
Avitec AB	Lucent Technologies
Böke & Walterfang Ltd	MAT Equipement
Celletra, Inc	Mitec Inc
Cellmax Technologies	O2 (UK) Ltd
CSA Ltd	PowerWave Technologies, Inc.
DAPA Systèmes SA	Proximus
Decibel Products Inc	Quintel Ltd
Elektrobit Ltd.	Racal Antennas Ltd
EMS Technologies, Inc	REMEC Inc
ETSA (Européenne de Télécommunications)	RFS Inc
Eyecom Technologies	RYMSA SA
Eyecom NZ Ltd.	Siemens AG
Filtronic Ltd	Sigma Wireless Technologies Ltd
Forem spa	T-Mobile International
Fractus SA	TIM
Gamma Nu Inc	University of Sheffield (UK)
Hitachi Cable Co Ltd	VIAG Interkom GmbH
Huber + Suhner Ltd	Vodafone Group
Huber + Suhner AG	Voxaura Technologies Inc
Jacquelot Technologies SA	Xi'an Haitan Antenna Technologies Co. Ltd

A number of aspects of this specification are subject to extension and development to accommodate new requirements. Members are recommended to consult the AISG Website (www.aisg.org.uk) for information on current or forthcoming updates.



1 SCOPE

This document defines a standard data interface at an antenna line device by means of which functional parameters of the device can be remotely controlled; specifically it defines the requirements of a three-layer protocol model. The three-layer model is a compact form of the OSI seven-layer reference model and includes only layers 1, 2 and 7. The advantage of this compact model is that it provides an efficient protocol stack suitable for implementation on a single embedded microcontroller.

Layer 1, the physical layer, defines the signalling levels, basic data characteristics including baud rate and the preferred input connector.

Layer 2, the data link layer, is based on a custom subset of the HDLC standard as defined in ISO/IEC 13239:2000(E).

Layer 7, the application layer, defines the data payload format and the required command set.

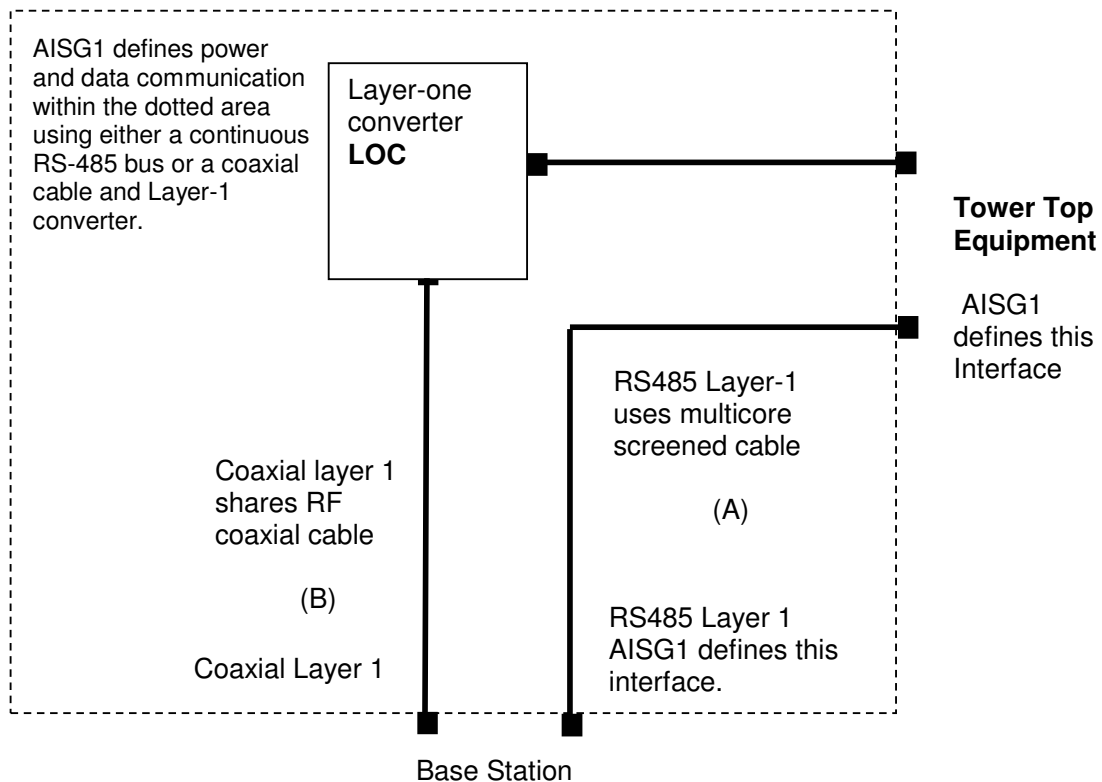

Figure 1: Schematic diagram showing the equipment and interfaces specified in this standard.

Figure 1 illustrates both a direct RS485 connection between a Node-B/BTS and tower-top equipment, and the alternative system (B) in which a coaxial cable is used to carry power as well as data and RF signals. When a coaxial cable is used it terminates at a



layer-1 converter (usually inside a TMA) and an RS485 data connection is made to the antenna.

In addition, this document defines recommended environmental parameters, together with recommended standards for safety, electromagnetic compatibility (EMC) and electromagnetic pulse (EMP).

Antenna line devices may include RET antennas, TMAs, boosters, VSWR measuring units and other tower-top equipment. All these (and others) can be implemented using the system described in this standard, but each *device class* (kind of equipment) needs separate definition according to its control and monitoring requirements.

This standard is applicable to equipment designed for operation in any type of mobile radio fixed infrastructure.



3 REFERENCES

This AISG standard incorporates provisions from other publications. These are cited in the text and the referenced publications are listed below. Where references are dated, subsequent amendments or revisions of these publications apply only when specifically incorporated by amendment or revision of this AISG standard. For undated references the latest edition of the publication referred to applies.

- 1 EMC Directive, 83/336/EEC
- 2 ETS 300 242 2 Radio equipment and systems (RES): Electromagnetic compatibility (EMC) for European digital cellular communications system (GSM 900MHz and DCS 1800MHz); Part 2: Base station radio and ancillary equipment
- 3 ETS 301 489 8 Electromagnetic compatibility and radio spectrum matters (ERM); Electromagnetic compatibility (EMC) standard for radio equipment and services; Part 8: Specific conditions for GSM base stations
- 4 ETS 301 489 23 Electromagnetic compatibility and radio spectrum matters (ERM); Electromagnetic compatibility (EMC) standard for radio equipment and services; Part 23: Specific conditions for IMT-2000 CDMA Direct Spread (UTRA) base station (BS) radio, repeater and ancillary equipment
- 5 IEC 60130-9 (Ed. 3.0, May 2000): Connectors for frequencies below 3 MHz – Part 9: Circular connectors for radio and associated sound equipment
- 6 IEC 60529 (Feb 2001): Degrees of protection provided by enclosures (IP Code)
- 7 IEC 61000-4-5 01-Feb-1995 Electromagnetic compatibility (EMC) - Part 4: Testing and measurement techniques - Section 5: Surge immunity test
- 8 IEC 62305-4 Protection against lightning – Part 4: Electrical and electronic systems within structures
- 9 IEC/TS 61312-4 Protection against lightning electromagnetic impulse – Part 4: Protection of equipment in existing structures.
- 10 ISO/IEC 646:1991 Information technology – 7-bit coded character set for information exchange
- 11 ISO/IEC 7498-1:1994: Information technology – Open Systems Interconnection Basic Reference Model: The Basic Model
- 12 ISO/IEC 8482:1993: Information technology – Telecommunications and information exchange between systems - Twisted pair multipoint interconnections
- 13 ISO/IEC 13239 (2nd Edition, March 2000): Information Technology – Telecommunications and information exchange between systems – High-level data link control (HDLC) procedures
- 14 RTTE Directive 99/5/EEC
- 15 TIA/EIA Telecommunications Systems Bulletin TSB89: Application guidelines for TIA/EIA-485-A, June 1998 (Telecommunications Industry Association)



4 ABBREVIATIONS

Where abbreviations or acronyms are used in this document they have the following meanings:

ADR	Address
AIB	Antenna interface bus (RS485)
AIC	Antenna interface connector
ALAP	Antenna line application protocol
ALD	Antenna line device
ASK	Amplitude shift keying
BER	Bit error rate
CRC	Cyclic redundancy check
DISC	Disconnect (frame type)
DM	Disconnected mode
EMC	Electromagnetic compatibility
EMP	Electromagnetic pulse
FCS	Frame checking sequence
FRMR	Frame reject (frame type)
HDLC	High-level data link control
I	Information (frame type)
INFO	Information (field name)
ISB	Idle state biasing
LOC	Layer one (1) converter
NRM	Normal response mode
NRZ-L	Non-return-to-zero level
OOK	On-off keying
Op mA	Operating current (mA)
OSI	Open systems interconnection, as described in ISO/IEC 7498-1
Q mA	Quiescent current (mA)
RET	Remote electrical tilt unit (antenna drive unit)
RR	Receive ready (frame type)
RNR	Receive not ready (frame type)
RS485	A physical interface conforming to ISO/IEC 8482 (ANSI-EIA RS485)
SNRM	Set normal response mode (frame type)
TMA	Tower-mounted amplifier
TMB	Tower-mounted booster
TTE	Tower-top equipment
TWA	Two-way alternate (half-duplex)
UA	Unnumbered acknowledgement (frame type)
UART	Universal asynchronous receiver/transmitter
UNC	Unbalanced operation normal response mode class
XID	Exchange ID (Frame type)



5 TERMINOLOGY AND DEFINITIONS

Where the following terms are used in this document, they have the meanings listed below.

Antenna interface bus	The RS485 bus defined in this standard.
Antenna interface connector	A data connector provided on a TMA/TMB for the purpose of providing a data connection to an antenna or other device.
Antenna line	A group of logical devices associated with one or more antenna systems, which may include antenna drives, amplifiers and other equipment.
Antenna Line Application Protocol	The application (Level-7) protocol defined in this AISG Specification.
Antenna line device	A generic term for an addressable physical device such as an antenna drive or amplifier
ASCII character	A character forming part of the International Reference Version of the 7-bit character set defined in ISO/IEC 646:1991
Bus address	The HDLC address of each device connected to an RS485 bus
Calibrate	Exercise the antenna drive unit over its entire range of travel to ensure fault-free operation and synchronise the measured and actual beam tilt of the antenna.
Configuration data	A stored table or function defining the relationship between the physical position of the drive and electrical beamtilt.
Device type	A 1-byte field identifying the type of a device, for example an antenna drive or amplifier (See Appendix B for a list of assigned device types).
Daisy chain	A connection method in which a number of devices are sequentially connected to a single cable, corresponding electrical connections being made in parallel at each device.
Idle state biasing	The use of a bias voltage to define the logical state of an RS485 bus when no signal is present.
Layer-1 converter	A device providing a physical interface between a coaxial cable and the tower-top equipment (for example TMA, TMB, RET or other device).
Little-endian	The order of transmission in which the least-significant bytes of a multi-byte representation of a number are transmitted first.
On-Off keying	A simple modulation system in which a carrier is switched between two states, ON and OFF.
Return code	A response to a command contained in a single hex byte. (See Appendix C for a list of assigned return codes.) Most return codes indicate either successful completion of a command or a reason for its failure.
Reset	A process by which a processor, flash memory, FPGA or other device is returned to a known state of initialisation. This normally includes initialising ports, clearing the FPGA RAM, and for processors following the reset vector and commencing



Serial number	<p>execution at that address.</p> <p>An identifying alphanumeric designation for each product complying with this specification, assigned by the product manufacturer and having a maximum length of 17 bytes. The serial number is stored as ASCII characters (see above).</p>
	<p>Note that the combination of serial number and vendor code may be used to address antenna line devices on one or more complete mobile radio networks, so each vendor must manage the allocation of serial numbers to ensure they are never duplicated. The provision of the vendor code allows each vendor to manage serial numbers independently in accordance with their own established practice within the assigned field, the only constraint being that they are not repeated.</p>
Tilt (also downtilt, tilt angle, beamtilt)	<p>The angle between the direction orthogonal to the antenna axis and the maximum of its main beam in the elevation plane. A positive tilt angle means that the antenna beam is directed below the horizontal plane. An antenna has separate values for electrical and mechanical tilt. In the case of an antenna with an RET facility the electrical tilt is variable and is controlled by the interface described in this specification. The mechanical tilt is fixed by the geometry of the installation. In this specification the tilt referred to is always the electrical tilt unless otherwise stated.</p>
Vendor code	<p>A unique ASCII 2-character code assigned by AISG to each vendor manufacturing products conforming to this specification (See Appendix A for a list of assigned vendor codes).</p>



1. LAYER 1

This standard specifies two layer-1 connection alternatives to antenna line devices (ALDs):

1. A screened multicore cable, which may be used with any ALD and supports a conventional RS485 serial multi-drop bus.
2. A connection to an ALD by way of a coaxial cable which is shared with DC supply and RF signals

Both layer-1 options support the connection of two-way serial data and DC power to the ALDs. Three alternative DC supply voltages are specified.

Interconnection between the two specified layer-1 implementations is supported by a layer-1 converter (LOC).

6.1 Antenna line network

The RS485 implementation of layer-1 supports the connection of multiple ALDs forming an ALD network. Connections to multiple devices can be made using star or daisy-chain configurations.

When the connection topology requires one ALD to pass current to other downstream ALDs, it is important to ensure that each ALD can support the downstream current requirement.

6.1.1 Network current consumption

The total current consumption of an antenna line network is not specified as it will depend on the size of the network, the ALDs used and the primary station software design.

6.1.2 Maximum ALD network current demand

A RET will exhibit high current consumption only for controlled and limited periods. An ALD network may therefore be designed to support a total current consumption that is lower than the sum of the maximum consumption of each ALD. It is the responsibility of the ALD controller (ie the primary station) to avoid overload and secure a stable operating voltage for the ALDs. Specifically the primary station must ensure that high current devices such as RETs are not operated simultaneously.

6.1.3 Overcurrent protection

No short circuit protection capability is specified in this standard for separate ALDs. Attention is drawn to the need to avoid by design the possibility of damage to ALDs or interconnecting cables by short circuit faults, and to reduce the possibility of multiple devices being disabled by a single fault.



6.2 Interface Connector types

A multi-core cable connection to an ALD and its pin connections shall conform with Para 6.2.1.

6.2.1 Multi-pole connector

Type: 8-pin circular connector conforming to IEC 60130-9 - Ed. 3.0 with screw-ring locking.

Environmental rating: IP67 with or without fitted cap

Current rating: Capable of supporting a current of 3.5A on any pin

Pin connections are defined in Table 6.2.1 below.

Pin Number	Signal	Comments
1	+12V DC nominal	
2	-48V DC nominal	Use is optional
3	RS485 A	
4	RS485 GND	Use is optional. Isolated from DC return and ground.
5	RS485 B	
6	+24V DC nominal	
7	DC return	Not grounded for RET units
8	N/C	Reserved for future use

The screening braid of the cable shall be connected to the grounded body of the ALD by way of the connector shell.

Table 6.2.1: Multi-pole connector pin-out

6.2.2 Polarity of multi-pole connectors

Each ALD shall be fitted with a minimum of one data connector. Additional connectors may be provided if preferred for 'daisy chain' applications.

The polarity of the multi-pole connector pins shall follow the principle that live male connector pins are not exposed at any point, thus typically:

Node-B / BTS: Where the RS485 interface is provided: Socket(s) with female pins;

TMA:

When the TMA constitutes a LOC: Output socket(s) with female pins;

When TMA control is to be independent of the RF cable: One input socket with male pins and optionally a second (output) socket with female pins;

RET units: One input socket with male pins and optionally a second (output) socket with female pins;



Interconnecting cables: Plug with male pins at one end
Plug with female pins at the other end.

The polarity of the thread on the retaining ring is specified in IEC 60130-9. Components with female connector pins are associated with a screw ring having a female thread; those with male pins are associated with a male locking thread.

6.3 DC supply

6.3.1 Supply voltage

For each nominal DC supply voltage all devices must operate over the following range:

- 12V: 10.0V to 15.0V
- 24V: 19.0V to 30.0V
- 48V: -39.0V to -57.0V (Operation from - 48Vdc is optional)

In the case where only RET Antennas and TMAs are used, the same power option is recommended for both devices in order to avoid the usage of DC/DC converters in the TMAs, LOC or in other tower top equipment.

6.3.2 Noise and ripple

Noise and ripple at the LOC Point B shall not exceed 100mV_{pp} (0.1 – 20 MHz). In any case the noise level should not lead to data transmission errors.

6.4 Current consumption

6.4.1 RET DC supply

Two classes of RET devices current consumption are specified:

Nominal voltage at RET	Class 1 current		Class 2 current	
	Operating	Quiescent	Operating	Quiescent
12Vdc	< 1000mA	< 100mA	< 1500mA	< 100mA
24Vdc	< 800mA	< 100mA	< 1000mA	< 100mA
- 48Vdc	< 400mA	< 15mA	< 600mA	< 30mA

6.4.2 TMA DC supply

Two classes of TMA devices current consumption are specified:

Nominal voltage at TMA:	Class 1	Class 2
12 Vdc	< 200 mA	< 800 mA
24 Vdc	< 150 mA	< 500 mA
- 48 Vdc	< 100 mA	< 300 mA



6.4.3 ALD network DC supply

DC current supply from a Node-B/BTS to an AISG-specified ALD network is specified with minimum supplied current and short circuit (s/c) protection maximum current limits:

Nominal network voltage	Class 1		Class 2	
	Current	s/c current	Current	s/c current
12 Vdc	> 1200 mA	< 3.5 A	> 2300 mA	< 3.5 A
24 Vdc	> 950 mA	< 3.5 A	> 1600 mA	< 3.5 A
- 48 Vdc	> 500 mA	< 3.5 A	> 900 mA	< 3.5 A

6.4.4 ALD DC Supply Start-up Surge

The power supply must be able to start or restart with a peak and static load corresponding to one TMA and one RET as defined below:

ALD (+12Vdc ALD network)	Class 1	Class 2
RET I peak (1/2 amplitude 0.5ms)	8A	10A
TMA I peak (1/2 amplitude 1ms)	0.5A	1.5A
Static load	250mA	900mA
ALD (+24Vdc ALD network)	Class 1	Class 2
RET I peak (1/2 amplitude 0.5ms)	8A	10A
TMA I peak (1/2 amplitude 1ms)	0.5A	1.5A
Static load	200mA	600mA
ALD (- 48Vdc ALD network)	Class 1	Class 2
RET I peak (1/2 amplitude 1ms)	5A	7A
TMA I peak (1/2 amplitude 1ms)	0.4A	1.0A
Static load	115mA	330mA

6.4.5 DC supply via LOC

Figure 6.4.5 shows the arrangement when TMA/LOC is connected to a RET, and specifies limiting values for the DC current and voltage at defined points..

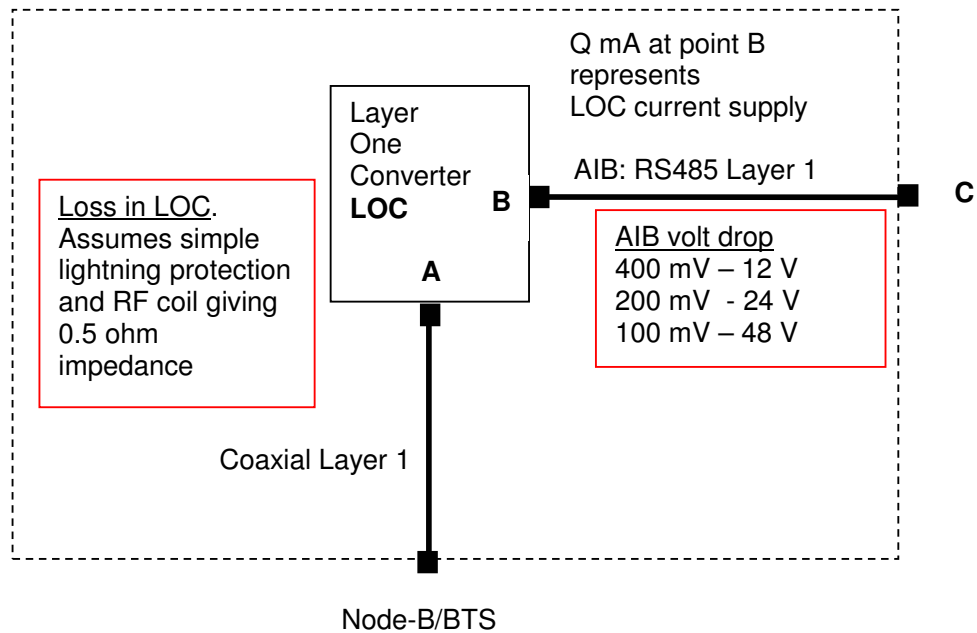

Figure 6.4.4: LOC and RET configuration

Assuming RET & TMA Class 1								
Point A			Point B			Point C		
Vdc	Op mA	Q mA	Vdc	Op mA	Q mA	Vdc	Op mA	Q mA
11.0	< 1200	< 100	10.4	< 1000	< 100	10.0 to 15.0	< 1000	< 100
19.7	< 950	< 100	19.2	< 800	< 100	19.0 to 30.0	< 800	< 100
-39.4	< 500	< 30	-39.1	< 400	< 15	-39.0 to -57.0	< 400	< 15

Assuming RET and TMA Class 2								
Point A			Point B			Point C		
Vdc	Op mA	Q mA	Vdc	Op A	Q mA	Vdc	Op A	Q mA
11.6	< 2300	< 150	10.4	< 1500	< 100	10 to 15	< 1500	< 100
20.0	< 1500	< 150	19.2	< 1000	< 100	19 to 30	< 1000	< 100
-39.6	< 900	< 45	-39.1	< 600	< 15	-39 to -57	< 600	< 30

Table 6.4.5: Current and voltage limits for a LOC/RET combination
 (refer to Fig 6.4.5) Note that the short-circuit and surge current requirements of 6.4.3 and 6.4.3 must also be observed.



6.4.6 Re-start capability of the power supply at a primary station

The power supply at a primary station and that, if any, at the LOC must be capable of starting normally when the connected devices each draw peak inrush currents as specified in Table 6.4.4.

6.5 RS485 serial data bus

6.5.1 Connections

The data bus shall be a two wire bi-directional multi-drop configuration conforming to ISO/IEC 8482:1993 (RS485). Pin connections are defined in Para 6.2.1. The use of RS485 GND (pin 4) is optional; this connection shall not be used as a DC supply return.

6.5.2 Device terminating impedance

It is not required for the RS485 to be terminated at the Antenna drive unit. Devices without termination connected to the bus should conform to the following parameters:

Resistance between RS485 A and RS485 B	> 1k ohm
Resistance between RS485 A or RS485 B and DC return / RS485 GND	> 1k ohm
Capacitance between RS485 A and RS485 B	< 1nF
Capacitance between RS485 A or RS485 B and DC/RS485 GND	< 1nF

6.5.3 Bus terminating impedance

An RS485 bus is preferably terminated in an impedance equal to the characteristic impedance of the cable used to connect bus devices together. Termination may be found to be unnecessary for short connections operating at low data rates and is therefore not mandatory.

6.6 Coaxial interface: modem characteristics

6.6.1 Interference with Existing Systems

The modem must not interfere with existing communications in BTS systems, so a unique carrier frequency for each different communication channel on a common feeder cable is necessary. It will be appreciated that each carrier is capable of supporting separate logical channels, each of which can support a separate RS485 bus.

The modem circuit must be capable of managing its transmitting characteristic (Para 6.6.6) and providing filtering for its receiver (Para 6.6.7).

The following frequency (referred to as f_0 in Fig 6.6.6.2) should be used for this application:

2.176 MHz +/- 100ppm



The frequency 4.5 MHz is reserved for future AISG purposes.

6.6.2 Data Rate

The modem shall support the data rates specified in Para 6.7.

6.6.3 Recovery Time

Due to hardware limitations a minimum recovery time must be allowed between transmitting and receiving messages on the bus. For this reason a minimum permitted response time is specified in Paragraph 7.10.3.

6.6.4 Impedance

The modem transceiver shall provide constant impedance in both transmitting and receiving modes

Nominal impedance Z_0 : 50 Ω

Return loss at nominal carrier frequency >6dB

6.6.5 Modulation

On-off-keying: Logical 1:Carrier OFF, Logical 0 Carrier ON

6.6.6 Modulator Characteristics

6.6.6.1 Levels

ON-Level: +3 dBm \pm 2 dB, OFF-Level: \leq -40 dBm

6.6.6.2 Spurious Emissions

Spurious emissions shall not exceed the mask shown in figure 6.6.6.2. Intermediate values may be obtained by linear interpolation between the points shown. In addition, out-of-band emissions must conform to the requirements of 3GPP TS25.104, ETSI TS05.05 and 3GPP TS 45.005 as applicable to the system.

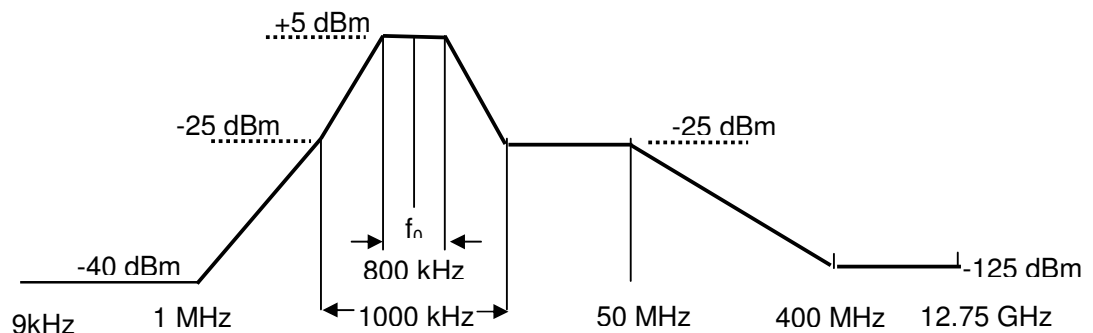

Figure 6.6.6.2: Spectrum mask for modems



6.6.7 Demodulator Characteristics

The demodulator characteristics have been defined on the assumption of a minimum separation of 2MHz for adjacent carriers on the same coaxial cable. This must be taken into consideration when choosing the operating frequency f_0 .

6.6.7.1 Threshold

Threshold: -15 dBm \pm 3 dB

6.6.7.2 Filter Characteristics

(To be reviewed for Issue 2)

6.6.7.3 Duty Cycle Variation

In order to guarantee proper transmission of data bits through the processes of modulation and demodulation, the duty cycle of the received binary data stream may not vary too much from that of the transmitted duty cycle. Specifically the following limit must be met:

$$\Delta DC_{SYSTEM} = |DC_{RX} - DC_{TX}| \leq 10\%$$

Where: ΔDC_{SYSTEM} is the difference between the duty cycles of the transmitted and received bit streams,

DC_{TX} = Duty cycle for the input bit stream, and
 DC_{RX} = Duty cycle for the output bit stream.

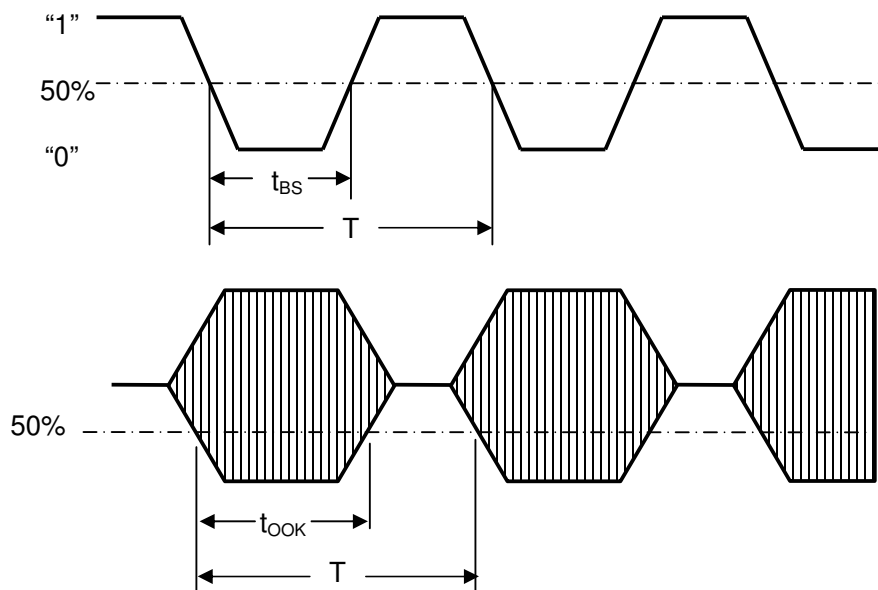

Duty cycle for bit stream = t_{BS}/T ; duty cycle for OOK = T_{OOK}/T

Figure 6.6.7.3: Duty cycles of the bit stream and OOK modulated subcarrier



For transmission through a coaxial cable, two converters are required, one from a bit stream to OOK (modulator) and one from OOK back to a bit stream (demodulator), so for each converter half of the total duty cycle tolerance is available.

For an input bit stream with a duty ratio of 50%, the cascaded modulator and demodulator must provide an output bit stream with a duty ratio within the limits 40% – 60%, measured in each case at 0.5 times peak amplitude (see Fig 6.4.7.3).

6.7 Data rate & format

6.7.1 Data Rate

The default data rate shall be 9.6kb/s. Higher data rates of 38.4kb/s and 115.2kb/s may optionally be supported. The operating data rate on a bus is established using the procedure described in Para 8.4.15.

6.7.2 Data Format

The format of the data shall be:

8 data bits	No parity
1 start bit	NRZ-L encoding
1 stop bit	

6.8 Resumption of operation after interruption of supply

The following provisions apply in the event of complete loss of DC supply or arbitrary reduction of the voltage supplied (brown-out).

6.8.1 Device Type 1 (RET)

Type 1 RETs have electromechanical phase shifters, which require DC power only for control functions. During loss of power antennas with Class 1 RETs continue in normal RF operation but will lose control functionality.

Normal operation shall be resumed after restoration of the power supply after any interruption. There shall be no loss of any stored data, including the current set tilt, nor shall there be any change in state such as a change of tilt, self-test or other autonomous operation.

If power is interrupted during a tilt change operation and as a result the position is lost or uncertain, then a PositionLost alarm must be generated on reconnection of power.

Type 1 RET systems may be left unpowered for extended periods and will be expected to resume normal operation as soon as power is applied.

6.8.2 Device Type 2 (TMA)

After restoration of power a TMA shall restart. There shall be no loss of stored data, including bypass mode or the set gain value (if the TMA supports adjustable gain), nor shall there be any change in state such as a self-test or other autonomous operation.



6.8.3 Device Type 3 (RET)

Type 3 RETs typically contain phase shifters which rely on continuous DC power to allow normal RF operation. In the event of the loss of DC power such antennas shall adopt a default status which shall be declared by the manufacturer.

Normal operation shall be resumed after restoration of the power supply after any interruption. There shall be no loss of any stored data, including the demanded tilt at the point at which power was interrupted, and any procedures necessary to restore normal operation shall not require the sending of additional commands to the device.

6.9 Idle-state biasing

The use of idle-state biasing (ISB) is not mandatory, but all ALDs shall be capable of supporting its use. If ISB is implemented then the bias voltages shall be applied by the primary station or by an LOC connected to any separate RS485 bus.

Reference should be made to TIA/EIA TSB89 for implementation of idle-state biasing.



7 LAYER 2

The data link layer is based on a subset of HDLC which conforms to the requirements of ISO/IEC 13239: 2000. The implementation of this subset is described in Paragraphs 7.1 to 7.32 below.

7.1 HDLC Format

7.1.1 Operating Mode

The operating mode shall be normal response mode (NRM) with two way alternate (TWA) communication. This mode requires that the primary station is always in control of the bus and the secondary station only answers frames sent by the master. The secondary station cannot send any frame independently.

The channel state shall be start/stop transmission.

7.1.2 Control octet transparency

Control octet transparency shall be implemented in accordance with ISO/IEC 13239 Para 4.3.2.2. This requirement applies to all frame types.

7.2 Frame checking sequence (FCS) field

The FCS shall be calculated in accordance with ISO/IEC 13239 on all bytes following the start flag up to, but not including, the CRC field.

7.3 HDLC Command Sub-set

The protocol shall as a minimum support the following HDLC commands. This command set is based upon the TWA, UNC (no options) commands list provided in Annex D of ISO/IEC 13239 (UNC15, UNC15.1 and TWA).

Commands (Primary Station)	Responses (Secondary Station)
Frame type I	Frame type I
Frame type RR	Frame type RR
Frame type SNRM	Frame type UA
Frame type DISC	Frame type DM
Frame type XID	Frame type RNR
	Frame type FRMR (optional)

Table 7.3: Frame types implemented in this standard



7.3.1 I-frame and INFO-field format

The I-frame and INFO-field formats for both primary and secondary stations shall be as illustrated in Table 7.3.1. INFO-fields are only used with I-frames.

The Frame Control Field shall be formatted in accordance with ISO/IEC 13239 Para 5.3.1, Table 3.

HDLC-Frame:

Flag 8bit	ADR 8bit	Control 8bit	INFO N x 8bit	CRC 2 x 8bit		Flag 8bit
0x7E	Device Address	Control bits	Variable length (must support a maximum length of at least 74 bytes)	CRC1 low byte	CRC2 high byte	0x7E

AISG	Command ID	Number of data bytes		Data bytes
Version ID	1 byte	low byte	high byte	Variable length (must support a maximum length of at least 70 bytes)

Table 7.3.1: Format of the I-Frame and INFO Field

Devices shall support the following data length:

Mandatory: $0 \leq \text{data bytes} \leq 70$

Optional: $0 \leq \text{data bytes} < 65,535 \text{ bytes}$

7.3.1.1 Parameter determination

To allow for the use of frames longer and window sizes larger than the default sizes the following layer 2 XID-frame may be sent by the primary to determine the maximum information field length and window size supported by a secondary. (Refer also to the referenced standard ISO 13239 Para 5.5.3.)

XID Frame from primary:

Field	Content	Description
ADDR	#	Device address
CTRL	XID	Command
FI	0x81	Format identifier
GI	0x80	HDLC Parameters set
GL	1	Length of the parameter field (PI)
PI	5	Parameter 5 = Maximum I field length Transmit
PL	Ntx	Length of the PV field (bytes)



PV	Value	Maximum I field length Transmit
PI	6	Parameter id6 = Maximum I field length Receive
PL	Nrx	Length of the PV field (bytes)
PV	Value	Maximum I field length Receive
PI	7	Parameter id7 = Maximum window size Transmit
PL	N	Length of the PV field
PV	Value	Maximum window size Transmit
PI	8	Parameter id8 = Maximum window size Receive
PL	N	Length of the window size
PV	Value	Maximum window size Receive

Response from secondary

The secondary device checks to see if it can support the values provided in the command. If the secondary can support the values then it replies with the same value. If the secondary can not support these values then it replies with the maximum values that can be supported:

Field	Content	Description
ADDR	#	Device address
CTRL	UA	Command
FI	0x81	Format identifier
GI	0x80	HDLC Parameters set
GL	Length	Length of the PI field
PI	5	Parameter id5 = Maximum I field length Transmit
PL	Ntx	Length of the PV field (bytes)
PV	Value	Maximum I field length Transmit
PI	6	Parameter id6 = Maximum I field length Receive
PL	Nrx	Length of the PV field (bytes)
PV	Value	Maximum I field length Receive
PI	7	Parameter id7 = Maximum window size Transmit
PL	N	Length of the PV field (bytes)
PV	Value	Maximum window size Transmit
PI	8	Parameter id8 = Maximum window size Receive
PL	N	Length of the PV field (bytes)
PV	Value	Maximum window size Receive

If the secondary does not provide a valid response, then the default frame length and window size are to be used.



7.3.2 Version ID

The version ID shall be used to identify the version of the AISG Layer 7 instruction set supported by the secondary station. It shall be set as 0x01 for equipment conforming to the first formal issue (Issue 1) of this specification.

7.4 HDLC Address

The HDLC address shall be stored in non-volatile memory and restored on power-up. The secondary station compares its own address with the Address field of the received frames from the bus. If the addresses are equal the frame is accepted and will be processed.

There is no response from secondary stations to broadcast addresses.

Two addresses are reserved for device management, these are:

7.4.1 Address 0x00

Address 0x00 is the initial state during installation. It is recommended that all devices be assigned this address by the manufacturer prior to shipment to the customer unless otherwise agreed by prior arrangement.

7.4.2 Address 0xFF

Address 0xFF is a broadcast address. All devices connected shall process commands received via a broadcast.

7.4.3 Address configuration

Before communication can be established on a bus it is necessary to configure the addresses of the devices connected to it. Address assignment is mediated by the use of an XID frame carrying data fields as specified in ISO 13239 Para 5.5.3.

7.4.3.1 Address Assignment Command

The format of the XID frame originated by the primary station shall be as follows:

Field	Content	Description
ADDR	0xFF	Broadcast
CTRL	XID	Command
FI	0x81	Format identifier
GI	0xF0	User defined parameter set
GL	n+5	Length of parameter field
PI	1	Parameter id 1 = unique id
PL	n	Length of PV field in bytes
PV	unique ID	Vendor id/serial number (n bytes)*
PI	2	Parameter id 2 = address
PL	1	Length of PV field in bytes
PV	1 – 254	Assigned address



7.4.3.2 Address Assignment Response

The secondary verifies FI, GI, GL and PI, PL for the two parameters. It then checks the first PV to see if it contains the its own unique ID. If so it changes its address to the one supplied in the second PV. It then responds with a UA frame transmitted from its new address.

Field	Content	Description
ADDR	#	Device address
CTRL	UA	Command

If the first PV does not match its unique ID, but the secondary already uses the address specified in the second PV, it changes its address to zero in order to remove itself from the bus. This prevents a situation in which two devices have the same address. It may be noted that this mechanism can used to reset a device's HDLC address to zero if it is to be removed from the bus.

If neither the first PV nor the second PV matches, the secondary does nothing.

After the assignment of its address a secondary remains in the disconnected state.

7.4.3.3 Device Scan Command

In some situations it may be found that the unique ID of a bus device is unknown or has been inaccurately recorded. This HDLC command exchange is used by the primary to perform a binary tree scan of the bus, in order to identify all connected devices, and is always carried out at 9.6kb/s.

7.4.3.3.1 Primary command (XID frame)

ADDR	0xFF	Broadcast
CTRL	XID	Command
FI	0x81	Format identifier
GI	0xF0	User defined parameter set
GL	2*n+4	Length of parameter field
PI	1	Parameter id 1 = unique id
PL	n	Length of PV field in bytes
PV	unique id	Vendor id/serial number (n bytes)
PI	3	Parameter id 3 = bit mask
PL	n	Length of PV field in bytes (same as for PI=1)
PV	bit mask	Bit mask (n bytes)

7.4.3.3.2 Device Scan Response (UA)

ADDR	#	Device address
CTRL	UA	Command
FI	0x81	Format identifier
GI	0xF0	User defined parameter set
GL	n+5	Length of parameter field
PI	1	Parameter id 1 = unique id
PL	n	Length of PV field in bytes
PV	unique id	Vendor id/serial number (n bytes)



PI	2	Parameter id 2 = address
PL	1	Length of PV field in bytes
PV	1 – 254	Address
PI	4	Parameter id 4 = device type
PL	2	Length of PV field in bytes
PV	XX	Device type

When each secondary receives the command it masks its unique id with the bit mask and compares the result with the unique id supplied. If they match, the secondary responds. It is recommended that the response of individual devices is subject to a random delay (within the permitted response time) to aid collision detection at the primary. The transmission of the device type (parameter 4) may not be supported by some older devices.

If there is no response, the primary knows that no secondary had those bits in its unique id, so the tree scan can be truncated at that branch.

If multiple secondaries respond, the messages may arrive after each other or at the same time. In the first case multiple responses will arrive before the timeout, in the second case the responses might garble each other, unless one secondary is close enough to overpower the signal from the other(s).

If any response arrives, a single frame, multiple frames or frames with incorrect checksums or framing errors, the primary must assume that that branch of the tree is inhabited and scan through it.

The design of the scanning procedure is not defined here.

7.5 Window Size (minimum)

The minimum window size is 1.

7.6 Connection Establish

The primary station sends an SNRM-frame to the secondary station. The secondary station responds with a UA-frame, its message buffers are emptied, HDLC sequence numbers are re-set and it enters the connected state. After the primary station receives the UA-frame, the corresponding secondary station is administered as connected.

7.7 Disconnect

The primary station sends a DISC-frame to the secondary station. The secondary station responds with a UA-frame and enters the disconnected state. After the primary station receives the UA-frame, the corresponding secondary station is administered as disconnected.

If the secondary station is in disconnected mode, it shall respond as defined in ISO 13239 Para 5.2.2.1.

7.8 Polling

Before any secondary station can be polled, it must first be placed in the connected state (Para 7.6). The primary station polls at time intervals as defined in paragraph 7.10.1.



On reception of a frame with correct FCS and matching address and with the poll-bit set, the secondary station is required to transmit frames on the bus within the times defined in Para 7.10.2.

If the secondary station has an I-frame to transmit it shall do so. If it does not have an I-frame to transmit it shall respond with either an RR or RNR frame. If it is unable to receive I-frames, for instance because it has run out of empty buffers, it shall respond with RNR. Otherwise it shall respond with RR. Please study Appendix B in Reference 13 for more details.

This polling procedure provides layer 7 with a full-duplex link, allowing layer 7 to spontaneously transmit messages, such as alarm messages. (For details of the layer 7 alarm messages, please refer to Para 8.4.6).

If the secondary does not receive a poll within 3 minutes of the previous poll, it may optionally perform a reset.

In the event that the primary station receives no responses from a secondary station, it is recommended that it signals loss of connection to its master.

7.9 Information

Before any secondary station can be required to send or receive an I-frame, it must first be placed in the connected state (Para 7.6). One I-frame is used for one message, so fragmentation is not required. If the primary station sends a command to the secondary station, one I-frame is generated and sent. The secondary station can respond with any valid HDLC response belonging to the subset implemented in this standard.

7.10 Message timing

7.10.1 (Not used)

7.10.2 Secondary Station Frame response

The primary station should receive a complete response frame within 10ms plus the time taken for the transmission of 100 bytes from the time the final flag byte is transmitted. The secondary station should start to transmit a response within 10ms. The time occupied by the transmission of 100 bytes allows time-outs to include transmission time, with 10ms allowed for processing.

7.10.3 Message timing

A minimum of 3ms must elapse between transmitting and receiving messages on a bus.

7.11 Frame Error Rate

The number of frames detected with incorrect checksums shall be less than 1 frame in 5000 frames.



8 LAYER 7

8.1 Command Format

Apart from address configuration, which uses the XID frame, commands to devices are transmitted within the HDLC INFO-field. The general format for all commands is the following:

Command	Number of data bytes	Data bytes
1 byte	2 bytes	max 70 bytes (basic implementation)

8.2 Response format and return codes

All responses from devices are transmitted in the HDLC INFO field. The general format for all responses is the following:

Command	Number of data bytes	Data bytes
1 byte	2 bytes	max 70 bytes (basic implementation)

The maximum time for all responses shall be 1 second unless specified in the individual command. Tilt setting, calibration and self test will typically require a longer period for completion of the command.

One or more return codes are transmitted in the data bytes.

A complete annotated table of all available return codes with their corresponding hexadecimal numbers is provided in Appendix C of this specification.

8.3 Overview of commands

This standard provides for a set of command-oriented instructions and also provides facilities to read and write data to specified locations in the memory of the secondary stations.

Global Commands	Command number	Global Commands	Command number
(Reserved)	0x01	Disable Device	0x09
Get Device Type	0x02	Self Test	0x0A
Reset	0x03	Read Memory	0x0B
Get Error Status	0x04	Write Memory	0x0C
Get H/W & S/W Info	0x05	Get Supported Bit Rates	0x0D
Clear Alarms	0x06	Set Device Data	0x0E
Alarm	0x07	Get Device Data	0x0F
Enable Device	0x08		

Table 8.3a: Mandatory global commands



Optional commands	
Software Download command sequence:	Command number
Download Start	0x2E
Store Data Start	0x20
Store Data Block Seg	0x21
Download End	0x22
Set Bit Rate	0x24

Table 8.3b: Optional global commands

Device specific commands (RET)	
Command	Command number
Calibrate	0x31
Send Config data	0x32
Set Tilt	0x33
Get Tilt	0x34

Table 8.3c: RET-specific commands

Device specific commands (TMA)	
Command	Command number
Set TMA Mode	0x40
Get TMA Mode	0x41
Set TMA Gain	0x42
Get TMA Gain	0x43

Table 8.3d: TMA-specific commands

8.3e Vendor specific commands: Command number 0xFF
(see Para 8.7 for implementation)



8.4 Global Command Interface – Mandatory for all Devices

In order to achieve interoperability, the following defined commands must be implemented in each antenna-line device. RETs, TMAs and other antenna-line devices attached to the RS485 bus are designated as secondary stations, which must all support following the commands.

In response to all layer-7 commands from the primary station, the addressed secondary station shall respond with <OK> whenever a normal outcome to the command has resulted, and <FAIL> otherwise. Additional parameters may be associated with the response <OK> and a variety of defined return codes (error messages) with the response <FAIL> as described in the following paragraphs. Return codes are also used as autonomous alarm responses (see Para 8.4.7 for details). A summary table and interpretation of all defined return codes is provided in Appendix C. When return codes are used, they shall have meanings consistent with those described. Some return codes are common to all device types; others are specific to a particular device type.

All alphanumeric fields shall use ASCII characters, using the character set defined in Section 5 of this specification.

A primary station (any control equipment, Node-B, &c) must execute two procedures for each secondary station (RET, TMA, &c) before control of the secondary station is possible:

1. The HDLC address must be assigned to the secondary station, and
2. The device type of the secondary station must be requested, so the primary can identify the appropriate command set to with which to communicate with the secondary device.

8.4.1 Get Device Type Command Name: GetDevType

This command requests the type of a network device. A scan of all correctly configured and connected devices connected to the RS485 bus may be initiated by sending the command GetDevType to each address and evaluating the responses.

Data field command to secondary station:

0x02 0x00 0x00

Data field response from secondary station:

0x02 <LengthLowByte> <LengthHighByte> <OK> <VendorLowByte> ..
<VendorHighByte> <DeviceType>

Vendor codes and device types are defined in Appendix A and B respectively.

Data field response from secondary station in case of error in performing the command:

0x02 <LengthLowByte><LengthHighByte><FAIL> <ReturnCode1>..<ReturnCodeN>



8.4.2 Reset Software Command Name: Reset

This command resets the device software, restarts the software and places the device in the disconnected state.

Data field command to secondary station:

0x03 0x00 0x00

Data field response from secondary station before the reset command is executed:

0x03 0x01 0x00 <OK>

The device must not execute the reset before layer-2 acknowledgement through sequence number update is received for the response. See Ref 13, Appendix B.

The Reset command must be executed in all situations. The secondary must not fail to reset because it is busy or for an other reason of its software state.

8.4.3 Error Detection Command Name: GetErrorStatus

This command-requests the error status information from a secondary station.

Data field command to secondary station:

0x04 0x00 0x00

Data field response from secondary station:

0x04 <LengthLowByte> <LengthHighByte> <OK> <ReturnCode1>..<ReturnCodeN>

This is a normal response. The request to get status has been executed correctly and the response codes relate to parameters which relate to the operational parameters of the device. If there are no operational errors, no return codes follow <OK>.

Data field response from secondary station in case of error in performing the command:

0x04 <LengthLowByte> <LengthHighByte> <FAIL> <ReturnCode1>..<ReturnCodeN>

This is an abnormal response. The error codes relate to the reason for the inability of the unit to correctly execute the command and return the requested information.

8.4.4 Read Hardware and Software Information Command Name: GetInfo

This command reads hardware information and the software version from a secondary station. This information is initially written to each piece of connected equipment by the vendor. The software version must indicate the version number of the currently installed software, whether installed at the time of manufacture or during subsequent upgrade.



Data field command to secondary station:

0x05 0x00 0x00

Data field response from secondary station:

0x05 <LengthLowByte> <LengthHighByte> <OK> <Length> <ProdNr> <Length >
<SerNo> <Length > <HWVersion> <Length> <SWVersion>

ProdNr is the product type number and SerNr is the unique serial number of the individual unit.

HWVersion and SWVersion refer to the version designators of the hardware and installed software of the secondary station. If the application is missing or no version number is found, then an empty string shall be returned as the version number.

Data field response from secondary station in case of error in performing the command

0x05 <LengthLowByte> <LengthHighByte> <FAIL> <ReturnCode1>..<ReturnCodeN>

8.4.5 Clear stored Alarms

Command Name: ClearAlarms

This command clears alarm information which is stored in the secondary station.

Data field command to secondary station:

0x06 0x00 0x00

Data field response from secondary station after clearing the alarm flags:

0x06 0x01 0x00 <OK>

Data field response from secondary station in case of error in performing the command

0x06 <LengthLowByte> <LengthHighByte> <OK> <ReturnCode1> .. <ReturnCodeN>

8.4.6 Poll response from Secondary Station

Response Name: Alarm

Layer 2 provides a virtual full-duplex link to layer 7 (see Para 7.8). This virtual full-duplex link is used to simplify alarm reporting.

The secondary station reports every change in error status by transmitting an alarm message in response to a poll. Formally this is a response message, even though (on layer 7) it is a spontaneous message. There is no layer 7 command to request an alarm response message.

The alarm message contains a list of error-code/state-flag pairs. The state flag indicates that the error has occurred (StateFlag = 1) or cleared (StateFlag = 0).

Only error codes whose state has changed shall be included in the list. The secondary station may group several error codes into one message, but their sequence in the message must then reflect the sequence in which they occurred.



A rapid setting/clearing sequence of the same alarm may be reported in the same alarm message in the order in which they occurred (FIFO).

In the event that the rapid state changes cause overflow of the available buffers, the oldest error code changes shall be discarded and the later ones retained for transmission.

Autonomous data field response from secondary station if an error state has changed since the previous poll from the primary station:

0x07 <LengthLowByte><LengthHighByte><ReturnCode1><StateFlag1>....
...<ReturnCodeN> <StateFlagN>

Alarm return codes are defined in Appendix C.

8.4.7 Enable Device

Command Name: Enable

This command enables a device (secondary station) for operation. If a device is enabled, all commands are executable; if it is already enabled, a second enable command will be accepted without error and the device will remain enabled. Internally, the status of the device is always set to **enabled** after the command is received.

Data field command to secondary station:

0x08 0x00 0x00

Data field response from secondary station:

0x08 0x01 0x00 <OK>

Data field response from secondary station in case of error in performing the command:

0x08 <LengthLowByte> <LengthHighByte> <FAIL> <ReturnCode1>..<ReturnCodeN>

8.4.8 Disable Device

Command Name: Disable

This command secures devices against unauthorised or accidental change of operational parameters. When a device is disabled, commands which SET parameters will not be accepted and an DeviceDisabled error will be returned. If it is already disabled, a second disable command will be accepted without error and the device will remain disabled. Internally, the status of the device is always set to **disabled** after the command is received.

All devices shall be delivered by vendors with their status set to 'disabled'. The status of every device after reset shall default to 'disabled'.

Data field command to secondary station:

0x09 0x00 0x00



Data field response from secondary station:

0x09 0x01 0x00 <OK>

Data field response from secondary station in case of error in performing the command:

0x09 <LengthLowByte> <LengthHighByte> <FAIL> <ReturnCode1>..<ReturnCodeN>

8.4.9 Self Test

Command Name: SelfTest

This command executes a test function at the device which may include a check of physical and processor functions.

The response from the command provides the user with information on detected faults or, if no fault is detected, with confidence that the operation of the device is normal in all respects.

During the test the operational parameters of the device shall not change beyond operationally acceptable limits and on completion all parameters shall be returned to their initial values.

Data field command to secondary station:

0x0A 0x00 0x00

Data field response from secondary station:

0x0A <LengthLowByte><LengthHighByte><OK><ReturnCode1>..<ReturnCodeN>

This is a normal response in which the self test was executed with return codes set to report possible detected functional errors during the test. If no errors are detected, this shall be signalled by no return codes following <OK>.

Data field response from secondary station in case of error in performing the command:

0x0A <LengthLowByte><LengthHighByte><FAIL><ReturnCode1>..<ReturnCodeN>

In this case the self test could not be executed and the return codes relate to the inability of the device to perform the requested self-test operation.

8.4.10 Read and Write Memory

8.4.10.1 Read Memory

Command name: ReadMemory

Data field command to secondary station:

0x0B <LengthLowByte> <LengthHighByte> <MemoryAddressByte1>
<MemoryAddressByte2> <MemoryAddressByte3> <MemoryAddressByte4>
<n = number of bytes to read>



Data field response from secondary station:

0x0B <LengthLowByte><LengthHighByte><OK> <MemoryAddressByte1>
<MemoryAddressByte2> <MemoryAddressByte3> <MemoryAddressByte4>
<byte1> ... <byteN>

Data field response from secondary station in case of error in performing the command:

0x0B <LengthLowByte> <LengthHighByte> <FAIL> <Return Code (s)>

MemoryAddress bytes are transmitted in little-endian order.

8.4.10.2 Write Memory

Command name: WriteMemory

Data field command to secondary station:

0x0C <LengthLowByte><LengthHighByte> <MemoryAddressByte1>
<MemoryAddressByte2> <MemoryAddressByte3> <MemoryAddressByte4>
<byte1> ... <byteN>

MemoryAddress bytes are transmitted in little-endian order.

Data field response from secondary station:

0x0C 0x01 0x00 <OK>

Data field response from secondary station in case of error in performing the command:

0x0C <LengthLowByte> <LengthHighByte> <FAIL> <ReturnCode1> <ReturnCodeN>

8.4.11 Get supported bit rates

Command Name: GetBitRates

This command is used to determine which bit rates are supported by any device connected to a bus. All systems shall respond to this command, but support for bit rates other than 9.6kb/s is optional. Devices which support multiple bit rates will reply with multiple values.

Data field command to secondary station:

0x0D 0x00 0x00

Data field response from secondary station:

0x0D <LengthLowByte>0x00 <OK> < BitRateByte1>< BitRateByte2>< BitRateByte3>

Bit rate byte:

0x00 : 9.6kb/s

0x01 : 38.4kb/s

0x02 : 115.2kb/s

Data field response from secondary station in case of error in performing the command:

0x0D <LengthLowByte> <LengthHighByte> <FAIL> <ReturnCode1>...<ReturnCodeN>



8.4.12 Set Device Data

Command name: SetDeviceData

This command is used to write data into the fields optionally provided for configuration data and listed in Appendix D. If an attempt is made to write to fields which are not supported by a particular device, no error is returned but the data for those fields is ignored.

Data field command to secondary station:

P0x0E <LengthLowByte><LengthHighByte><FirstParameterNumber> <data bytes for first parameter> <SecondParameterNumber> <data bytes for second parameter> <ThirdParameterNumber><data bytes for third parameter>.. ... <Nth ParameterNumber> <data bytes for Nth parameter>

Data field response from secondary station:

0x0E 0x01 0x00 <OK>

Data field response from secondary station in case of error in performing the command:

0x0E <LengthLowByte><LengthHighByte><FAIL> <ReturnCode1>...<ReturnCodeN>

8.4.13 Get Device Data

Command Name: GetDeviceData

This command is used to read data stored in the fields optionally provided for configuration data and listed in Appendix D. If an attempt is made to read fields which are not supported by a particular device no data is returned for that field. The command contains a list of the field numbers of those fields whose contents are to be returned in the response from the secondary station. The field numbers are not necessarily contiguous or ordered.

Data field command to secondary station:

0x0F <LengthLowByte><LengthHighByte><0x01 <0x02> <0x03> ... <0x0N>

Data field response from secondary station:

0x0F <LengthLowByte><LengthHighByte> <OK> <0x01><data bytes for parameter 1> <0x02> <data bytes for parameter 2> <0x03><data bytes for parameter 3>... <0x0N> < data bytes for parameter N>

Data field response from secondary station in case of error in performing the command:

0x0F <LengthLowByte><LengthHighByte><FAIL> <ReturnCode1>...<ReturnCodeN>

8.4.14 Software Download (Optional feature)

If software download is supported, then the following commands are used to download new software releases to a secondary station. The sequence of the following commands must be strictly observed. After the complete sequence a reset command is necessary to activate the new software.



For implementations in which more than one software data file will be downloaded to a secondary station, the address of the memory locations to be erased shall be transmitted in the header of the first data block of each data file.

The sequence of commands to effect a software download to a secondary station is illustrated in Appendix E of this standard.

8.4.14.1 Download Start

Command Name: DownloadStart

This command initiates internal copy and execution of software routines and may delete parts of the flash memory. An <OK> response indicates that any flash erasure has been successfully executed.

Data field command to secondary station:

0x2E 0x00 0x00

Data field response from secondary station:

0x2E 0x01 0x00 <OK>

Data field response from secondary station in case of error in performing the command:

0x2E <LengthLowByte> <LengthHighByte> <FAIL><ReturnCode1>.<ReturnCodeN>

8.4.14.2 Store Data Start

Command Name: StoreDataStart

This command specifies the block-number of the block which will be transferred and the number of bytes within this block.

Data field command to secondary station:

0x020 0x04 0x00 <BlockNrLSB> <BlockNrMSB> <BlockLengthLSB>
<BlockLengthMSB>

Data field response from secondary station:

0x20 0x03 0x00 <OK> <BlockNrLSB> <BlockNrMSB>

Data field response from secondary station in case of error in performing the command:

0x20 <LengthLowByte> <LengthHighByte> <FAIL> <BlockNrLSB> <BlockNrMSB>
<ReturnCode1> ... <ReturnCodeN>

8.4.14.3 Store Data Block Segment

Command Name: StoreDataBlockSeg

This command transfers data segments to the secondary station.

Data field command to secondary station:

0x21 <LengthLowByte> <LengthHighByte> <SegmentNumber> <data 1>...
<data n>

(comment: $n_{max} = 69$ if 74-byte I-fields are used)



Data field response from secondary station:

0x21 0x02 0x00 <OK> <SegmentNumber>

Data field response from secondary station in case of error in performing the command:

0x21 <LengthLowByte> <LengthHighByte> <FAIL> <SegmentNumber>
<ReturnCode1> ... <ReturnCodeN>

The segment number commences at 0 and is incremented in steps of 1 to a maximum value of 255. If more than 256 segments are required, a new block must be started which in turn resets the segment number to 0.

8.4.14.4 Download End

Command Name: DownloadEnd

With this command the primary station signals the end of software transfer to the secondary station. The secondary responds after verifying the checksum of the data transferred to memory.

Data field command to secondary station:

0x22 0x00 0x00

Data field response from secondary station:

0x22 0x01 0x00 <OK>

Data field response from secondary station in case of error in performing the command:

0x22 <LengthLowByte> <LengthHighByte> <FAIL> <ReturnCode1>.<ReturnCodeN>

8.4.15 Optional command: Set Bit Rate

Command name: SetBitRate

This broadcast command informs all connected secondary stations that the primary has been ordered to switch to the specified bit rate. The message shall not be repeated.

Data field command to secondary stations:

<0x27> 0x01 0x00 <bit rate byte>

Bit rate byte:

0x00 : 9.6kb/s

0x01 : 38.4kb/s

0x02 : 115.2kb/s

There is no response from secondary stations to this broadcast command until 5 further frames have been received.



8.4.15.1 Bit rate change procedure

It is mandatory that any secondary station that supports multiple bit rates is capable of supporting this procedure.

The primary station is not allowed to change the bit rate autonomously; it will generally be set during system configuration, or as an operator-mediated response to a communications failure, perhaps caused by physical damage to the bus. Secondary stations will operate at the specified bit rate and will check briefly for communication at other bit rates only if the bus has been quiet for a long period. The system provides a stable and reliable bit rate fallback scheme.

A secondary station that supports bit rates other than the mandatory 9.6kb/s must have a 1-minute LinelsDead timeout. This timeout must be re-set whenever the secondary receives a valid HDLC frame, regardless of its address. It must also have a FramingError counter and a BytesReceived counter. Both these counters must be reset to zero whenever a valid HDLC frame is received, regardless of its address.

As all devices support a bit rate of 9.6kb/s, communication can be established on the bus before a higher rate is set. The primary should first use the GetBitRates command to determine which higher bit rate(s) can be supported by all connected devices, as the maximum bus bit rate is determined by the slowest connected device. The primary is then set to operate at the new bit rate. It may be preferred to send a SetBitRate command before the primary rate is changed; this makes the subsequent procedure at the secondary stations faster but its use is optional.

If the LinelsDead timeout occurs at a secondary station its current bit rate is assumed to be invalid and the secondary shall initiate the bit rate test sequence as follows:

1. Set the bit rate to the maximum supported rate;
2. Clear the FramingError and BytesReceived counters;
3. Wait 10 seconds, or until a valid HDLC frame is received;
4. If any valid HDLC frame is received (regardless of its address) the sequence is terminated, but the bit rate is not stored until 5 further frames (regardless of their address) have been received;
5. If the FramingError and BytesReceived counters are zero, the bit rate is restored to the last stored bit rate and the sequence is terminated;
6. If the FramingError counter is at least 10 or the BytesReceived counter is at least 10 the bit rate is assumed to be wrong. If the bit rate is greater than 9.6kb/s the bit rate is reduced and the sequence continues with Step 2.
7. If the bit rate is already 9.6kb/s the bit rate is restored to the last stored bit rate and the sequence is terminated.

8.5 Device Specific Commands for a RET

8.5.1 RET Calibration

Command Name: Calibrate

This command is sent after installation of a RET. Calibration entails ensuring that the actuator is driven through its whole tilt range.



After reset or power failure no calibration is normally required. There may occasionally be unforeseen errors where calibration could be required to return the RET to a correct no-error status.

The response time shall be less than 4 minutes.

Data field command to secondary station:

0x31 0x00 0x00

Data field response from secondary station:

0x31 0x01 0x00 <OK>

Data field response from secondary station in case of error in performing the command:

0x31 <LengthLowByte> <LengthHighByte> <FAIL> <ReturnCode1>..<ReturnCodeN>

8.5.2 RET Send Configuration Data Command Name: SendConfigData

This command may be required after installation of any RET unless already performed by the vendor before delivery. It loads vendor and antenna specific configuration data to establish the relationship between the movement of the drive system and the beam tilt position of the antenna.

When specified by the vendor the data must be loaded during the installation procedure. (Typically this may be necessary because the same type of drive unit (RET) may be used in association with different antenna types, each requiring different configuration data.)

Data field command to secondary station:

0x32 <LengthLowByte> <LengthHighByte> <DataByte1> ... <DataByteN>

Data field response from secondary station:

0x32 0x01 0x00 <OK>

Data field response from secondary station in case of error in performing the command:

0x32 <LengthLowByte> <LengthHighByte> <FAIL> <ReturnCode1>..<ReturnCodeN>

8.5.3 RET Set Tilt Command Name: SetTilt

This command sets the electrical tilt value in increments of 0.1°.

The response time shall be less than 2 minutes.

The format of the demanded tilt shall be a 16 bit signed number. (See Section 5 for definition and sign convention.)

Data field command to secondary station:

0x33 0x02 0x00 <TiltLowByte> <TiltHighByte>



Tilt values are specified in 0.1° increments starting from zero, for example: Tilt 3.2° is 0x0020 (stored as <0x20><0x00>), Tilt - 3.2° is 0xFFE0, stored as <0xE0><0xFF>).

Data field response from secondary station:

0x33 0x01 0x00 <OK>

Data field response from secondary station in case of error in performing the command:

0x33 <LengthLowByte> <LengthHighByte> <FAIL> <ReturnCode1> ... <ReturnCodeN>

8.5.4 RET Get Tilt

Command Name: GetTilt

This command requests the current tilt value.

The response is made in increments of 0.1° in the format specified in Para 8.5.3.

Data field command to secondary station:

0x34 0x00 0x00

Data field response from secondary station:

0x34 0x03 0x00 <OK> <TiltLowByte> <TiltHighByte>

Data field response from secondary station in case of error in performing the command:

0x34 <LengthLowByte> <LengthHighByte> <FAIL> <ReturnCode1>..<ReturnCodeN>

8.6 Specific commands for a TMA

The TMA MODE commands are applicable to TMAs that support bypass.

The TMA GAIN commands are applicable to TMAs that support variable gain.

8.6.1 Set TMA Mode

Command name: SetMode

This command switches a TMA into and out of bypass mode. In bypass mode a suitable switch bypasses the amplifiers.

If a mode is already set, the command to set the mode will be accepted without an error and the TMA will remain in the specified mode.

Data field command to secondary station:

0x40 0x01 0x00 0x00 Set normal mode

0x40 0x01 0x00 0x01 Set bypass mode

Data field response from secondary station:

0x40 0x01 0x00 <OK>



Data field response from secondary station in case of error in performing the command:

0x40 <LengthLowByte> <LengthHighByte> <FAIL><ReturnCode1>...<ReturnCodeN>

8.6.2 GET TMA MODE

Command Name: GetMode

This command requests the operational status information from a secondary station.

Data field command to secondary station:

0x41 0x00 0x00

Data field response from secondary station:

0x41 0x02 0x00 <OK> 0x00 TMA in normal mode

0x41 0x02 0x00 <OK> 0x01 TMA in bypass mode

Data field response from secondary station in case of error in performing the command:

0x41 <LengthLowByte> <LengthHighByte> <FAIL> <ReturnCode1>...<ReturnCodeN>

8.6.3 Set TMA Gain

Command Name: SetGain

This command sets the gain of a TMA in increments of 0.25dB.

The format of the demanded gain shall be an 8 bit unsigned number. The number shall be calculated from zero dB (0x00) in increments of 0.25dB.

If the gain parameter is out of the available range, the gain remains unchanged and the TMA returns an error code (GainOutOfRange)

Data field command to secondary station:

0x42 0x00 0x01 <Gain>

Data field response from secondary station:

0x42 0x01 0x00 <OK>

Data field response from secondary station in case of error in performing the command:

0x42<LengthLowByte><LengthHighByte><FAIL><ReturnCode1>...<ReturnCodeN>

8.6.4 Get TMA Gain

Command Name: GetGain

This command gets the gain of the TMA in increments of 0.25dB.

The format of the gain shall be an 8 bit unsigned number. The number shall be calculated from zero dB (0x00) in increments of 0.25dB.



Data field command to secondary station:

0x43 0x00 0x00

Data field response from secondary station:

0x43 0x00 0x02 <OK> <Gain>

Data field response from secondary station in case of error in performing the command:

0x43 <LengthLowByte> <LengthHighByte> <FAIL> <ErrorCode1>...<ErrorCodeN>

8.7 Vendor Specific Commands

These commands which are vendor specific are internally implemented but are not used for control or telemetry functions. These commands are used for test and development, and are not published. All control and telemetry functions shall be accomplished using the commands specified in this standard.

Vendor Specific Commands and responses shall be formatted as follows:

0xFF <LengthLowByte> <LengthHighByte> <VendorID> (...remaining format and content vendor specific.)

8.8 Unknown Commands

If a secondary station is unable to recognise a command, the secondary station shall respond as follows:

INFO field command to secondary station:

<UnknownCommand> <LengthLowByte> <LengthHighByte> <Data1> ... <DataN>

INFO field response from secondary station:

<unknown command> 0x02 0x00 <FAIL> <ReturnCode>

8.9 Additional commands for control and telemetry

Members of AISG may at any time request the registration of additional commands, responses and parameters to manage control and telemetry functions not covered in the present command set as listed above. Such a request shall include:

1. The purpose of the commands and responses;
2. The syntax to be associated with the commands and responses;
3. Any other information which may allow all members of AISG to correctly implement the commands and responses in primary or secondary stations.

After an opportunity for comment by members, command response numbers and parameters will be allocated. This process will normally be completed within 25 working days of the receipt of a request. Details of all requests and adopted commands will be displayed on the AISG members' website (<http://www.aisg.org.uk>) before being incorporated into a later version of this standard. Requests for registration of commands and responses should be sent to the Chairman for the time being, or may be sent by e-mail to secretariat@aisg.org.uk.



9 ADDITIONAL REQUIREMENTS

9.1 Electromagnetic compatibility

It is recommended that all devices connected to the RS485 bus comply with the relevant parts of the following specifications:

ETS 301 489-8

ETS 301 489-23

ETS 300 342-2

EMC Directive 83/336/EEC

RTTE Directive 99/5/EEC

Tower-mounted equipment is required to operate in a very demanding EMC environment. In addition to meeting the requirements of these mandatory specifications, tower-mounted equipment complying with this specification must be capable of operation within the error rate defined in Paragraph 7.12 of this standard when subjected to an RF field with an intensity of 50V/m in the frequency bands 870 - 960MHz, 1710-1880MHz and 1920-2170MHz.

The operation of any control system complying with this specification shall not give rise to error bursts in the associated mobile radio receiver equipment.

9.2 Lightning protection

A tower-top environment presents a severe lightning threat to the reliable operation of sensitive low-voltage equipment. In order to ensure a satisfactory level of in-service reliability it is recommended that all tower-mounted equipment must be tested in accordance to one of the following specifications:

IEC 62305-4

IEC 61000-4-5

(IEC 62305-4 is currently incomplete; an interim standard which could be used is IEC/TS 61312-4).

9.3 Reliability

It is recommended that each RET be designed to have a reliability of at least 10,000 mean operations between failure.



10 PRODUCT IDENTIFICATION

10.1 Marking of conforming products

In order to allow users to identify products which conform with the requirements of this standard, member companies are encouraged to use the AISG logo on conforming products and on any brochures, advertisements or product literature associated with them. In addition, the legends 'AISG1' or 'Conforms with interface standard AISG1' may be used on such products and associated literature.

10.2 Use of the AISG name and logo

The name Antenna Interface Standards Group in full or in abbreviated form (AISG) and the AISG logo are the property of the Antenna Interface Standards Group and may not be used in connection with any current product which does not, nor any future product which will not conform with a published AISG standard.

10.3 Vendor ID and Serial Number

The combination of Vendor ID and product Serial Number form a unique identity for every antenna line device. Each vendor shall ensure that under no circumstances are serial numbers duplicated in their products. The use of the unique assigned Vendor ID allows each vendor to manage serial numbers independently of all other vendors.



APPENDIX A: ASSIGNED VENDOR CODES

The following two-letter codes are assigned to vendors for use in identifying products in accordance with the requirements of Paragraph 8.4.2 of this specification.

Vendor Code	Company name	Vendor Code	Company name
AA	Alcatel	HS	Huber + Suhner
AC	ADC, Inc	JB	Jaybeam Ltd
AD	Alan Dick & Co Ltd	JQ	Jacquelot Technologies
AL	Allgon Systems AB	KA	Kathrein KG
AN	Andrew Corporation	KL	K & L Microwave Inc
AT	Antenova Ltd	KM	KMW Ltd
AR	Argus Technologies (Australia) Pty Ltd	LA	LGP Allgon AB
AV	Avitec AB	LG	LGP AB
BW	Böke & Walterfang Ltd	LU	Lucent Technologies
CT	Celletra, Inc	MA	MAT Equipement
CX	Cellmax Technologies	MI	Mitec Inc
CS	CSA Ltd	MO	Motorola
DA	DAPA Systèmes SA	NK	Nokia
DB	Decibel Products Inc	NN	Nortel Networks
EB	Elektrobit Ltd	PW	PowerWave Technologies Inc
EM	EMS Technologies, Inc	QU	Quintel Ltd
ET	ETSA	RA	Racal Antennas Ltd
ER	Ericsson	RE	REMEC Inc
EY	Eyecom Technologies	RF	RFS Inc
FI	Filtronic Ltd	RY	RYMSA SA
FO	Forem spa	SH	University of Sheffield
FR	Fractus SA	SM	Siemens AG
GN	Gamma Nu Inc	SI	Sigma Wireless Technology Ltd
HI	Hitachi Cable Co Ltd	TH	Thales Antennas Ltd
		VX	Voxaura Technologies Inc
		XH	Xi'an Haitan Antenna Technologies Co Ltd

Other vendors wishing to manufacture equipment conforming to this standard may request the assignment of a Vendor Code by contacting: secretariat@aisg.org.uk



APPENDIX B: ASSIGNED DEVICE TYPES

The following 1-byte hexadecimal codes are assigned to devices for use in identifying the associated instruction set in accordance with the requirements of Paragraph 8.4 of this specification:

- 0x01 Antenna drive unit (RET)
- 0x02 Tower-mounted low-noise amplifier (receive only)
- 0x03 Antenna system requiring the continuous application of DC power for normal RF operation
- 0x04 Tower-mounted booster (transmit/receive)
- 0x05... Reserved for future use

Codes for additional device types will be added as required. Vendors requiring the definition of additional codes should contact: [secretariat @aisg.org.uk](mailto:secretariat@aisg.org.uk).



APPENDIX C: ASSIGNED RETURN CODES

The following return codes are defined in Layer 7

Code	Meaning		Domain
0x00	OK	Normal response	Global
0x01	Actuator Detection Fail	Signals from the actuator are detected but are abnormal, for example due to failed calibration.	RET
0x02	Actuator Jam Permanent	Actuator cannot be moved	RET
0x03	Actuator Jam Temporary	Actuator jam has been detected. No movement was detected in response to the normal stimulus.	RET
0x04	Block Number Sequence Error	Used in combination with software download; block number sequence is wrong.	Global
0x05	Busy	The device is busy and cannot respond until an activity is complete.	Global
0x06	Checksum Error	Used in combination with software download; checksum incorrect.	Global
0x07	Command Sequence Error	Used in combination with software download; command sequence is not permitted, eg a SetTilt command is received during software update sequence.	Global
0x08	Data Error	Layer 7 data fault, eg length of data is inconsistent with length fields.	Global
0x09	Device Disabled	Device is in logical Disabled state and cannot execute Set commands.	Global
0x0A	EEPROM Error	EEPROM error detected	Global
0x0B	Fail	Abnormal response. Indicates that a command has not been executed.	Global
0x0C	Flash Erase Error	Used in combination with software download. indicates error when erasing flash memory.	Global
0x0D	Flash Error	Used in combination with software download. indicates error when writing to flash memory.	Global
0x0E	Not Calibrated	The device has not completed a calibration operation, or calibration has been lost.	RET
0x0F	Not Scaled	No setup table has been stored in the device.	RET
0x11	Other Hardware Error	Any hardware error which cannot be classified.	Global
0x12	Other Software Error	Any software error which cannot be classified.	Global
0x13	Out of Range	Value specified by a Set Tilt command is not supported by the device.	RET
0x14	Position Lost	RET controller is unable to return a correct position value, for example there was a power failure while a SetTilt command was being executed.	RET
0x15	RAM Error	An error was detected in reading data to/from RAM	Global
0x16	Segment Number Sequence Error	Used in combination with software download; block sequence number is wrong.	Global



0x17	UART Error	Hardware specific. This error may be sent after recovery from a temporary error which has prevented the sending or receiving of data.	Global
0x19	Unknown Command	Received command is not defined in the version of AISG1 transmitted in the frame header, or the device has received a vendor-specific command with a vendor ID different from its own.	Global
0x1A	TMA Alarm Minor	An event has taken place that effects the TMA performance, the TMA continues to function and bypass is not implemented. (The actual performance degradation criteria must be vendor specified.)	TMA
0x1B	TMA Alarm Major	An event has taken place that renders TMA performance unacceptable. If bypass is fitted the TMA will switch into bypass.	TMA
0x1C	Gain out of Range	A SetGain command was received which specified a gain out side the range supported.	TMA



APPENDIX D ASSIGNED FIELDS FOR ADDITIONAL DATA

The following standard fields are used by the commands SetDeviceData and GetDeviceData. Little-endian order is used for storage of multiple-byte numbers. Where ASCII variables are shorter than the assigned field lengths the characters are right aligned and leading blanks are filled with null characters (0x00).

Field No.	Length (bytes)	Format	Description
Antenna data			
0x01	15	ASCII	Antenna model number
0x02	17	ASCII	Antenna serial number
0x03	2	16-bit unsigned	Antenna frequency band(s): see below
0x04	3	3 x 8-bit unsigned	Beamwidth for each band in frequency order (deg) (example 800/900MHz, 1800/1900MHz, 2100MHz)
0x05	3	3 x 8-bit unsigned	Gain for each band in frequency order (dB/10) (example 800/900MHz, 1800/1900MHz, 2100MHz)
0x06	2	16-bit signed	Maximum supported tilt (degrees/10), Format as Para 8.5.3.
0x07	2	16-bit signed	Minimum supported tilt (degrees/10), Format as Para 8.5.3.
TMA data			
0x11	15	ASCII	TMA model number
0x12	17	ASCII	TMA Serial number
0x13	1	8-bit unsigned	TMA type: see below
0x14	4	32-bit unsigned	TMA receive frequency band (see below)
0x15	4	32-bit unsigned	TMA transmit frequency band (see below)
0x16	1	8-bit unsigned	Maximum supported gain (dB/4)
0x17	1	8-bit unsigned	Minimum supported gain (dB/4)
0x18	1	8-bit unsigned	Gain resolution (=dB/16)
Operator data			
0x21	6	ASCII	Installation date
0x22	5	ASCII	Installer's ID
0x23	12	ASCII	Base station ID
0x24	4	ASCII	Sector ID
0x25	2	16-bit unsigned	Antenna bearing
0x26	1	8-bit signed	Installed mechanical tilt (degrees/10)



Fields 0x03 and 0x13

	Field 0x03	Field 0x13
Bit No	Frequency band(MHz)	TMA Type
1	800	Bypass
2	900	VSWR
3	1500	Reserved
4	1800	Reserved
5	1900	Reserved
6	2100	Reserved
7 and above	Reserved	Reserved

Examples of frequency bands: 00010000 = 1800MHz,
 00011100 = 1800, 1900 and 2100MHz

Fields 0x14 and 0x15:

<fmin low byte> <fmin high byte> <fmax low byte> <fmax high byte>

Where fmin and fmax are calculated in 100kHz steps from 0.



APPENDIX E: COMMAND SEQUENCE FOR DOWNLOAD OF SOFTWARE TO A SECONDARY STATION

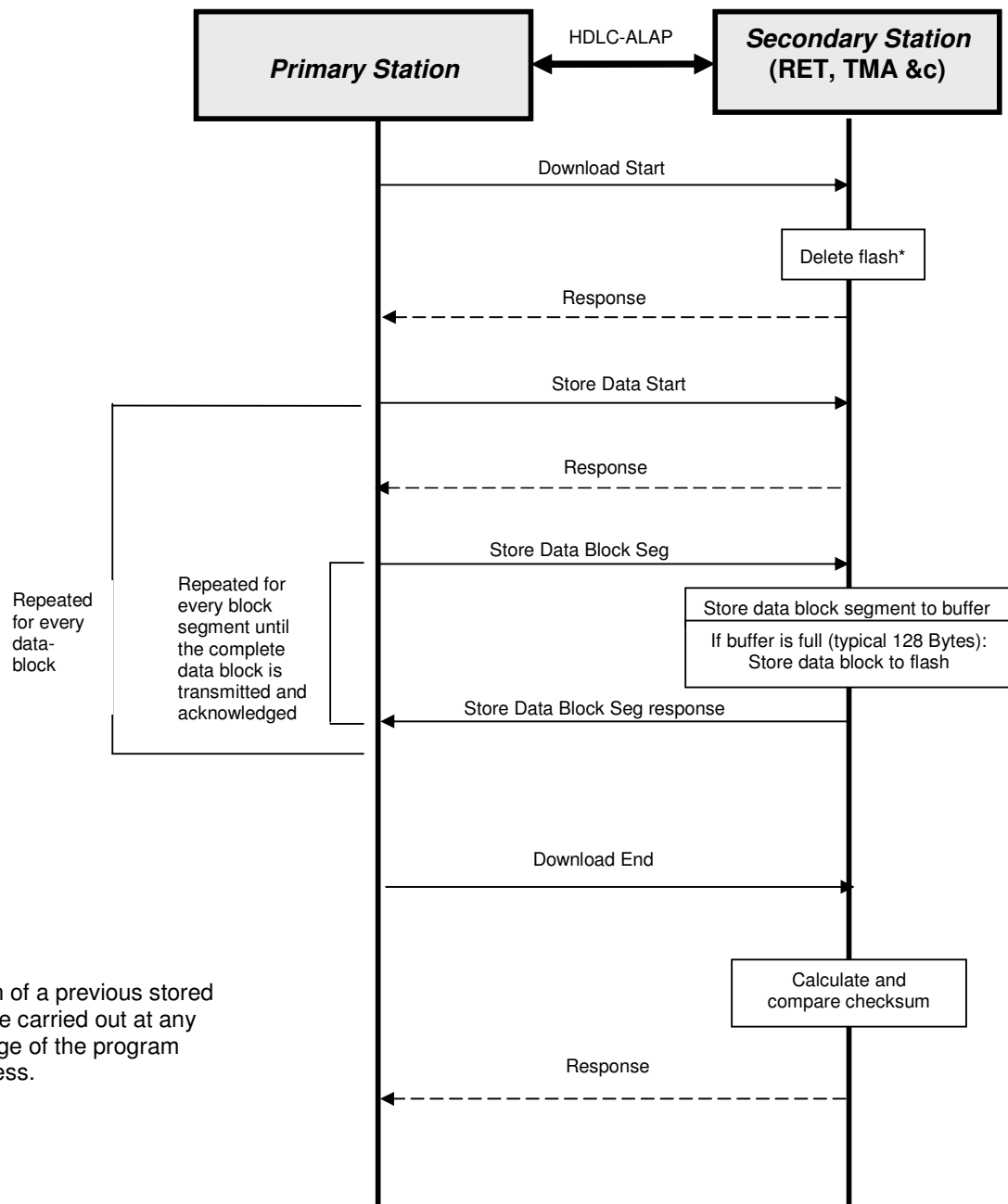



APPENDIX F: PRODUCT SPECIFICATION COMPATIBILITY

It is recommended that vendors claiming conformance with this specification supply a Compatibility Statement which sets out at least the following parameters:

Supported bit rates	_____ kb/s
Supply voltage(s)	_____ volts
Use of RS485 ground	Yes / No
Use of ISB	Yes / No
Power class	1 / 2
Reset after 3 minutes	Yes / No
Support for FRMR frames	Yes / No
Maximum frame length	_____ bytes
Maximum window size	_____ bytes
Frame length and window size negotiation supported	Yes / No
Support for software download	Yes / No
Number of bytes of user data	_____
Number of user data write cycles	_____
Response time for self test	_____ minutes
Device data field support	Yes / No
Settable device data fields	_____
Interface type	Coax / RS485
Number of RS485 connectors	1 / 2
Device type parameter in device scan response	Yes / No